

Grob G 103 C Twin III Acro

s/n: 34197
 Registration: G - CLXH

Notes to Pilot Operating Handbook:

This aircraft has **not** had modification AD 2006-057, OSB 315-66 (fuselage stiffening) carried out. MSB 315-65 applies to this aircraft.

All aerobatics including spins are **prohibited**.

Cloud flying is **prohibited**.

The POH has sections with different performance parameters depending on the modification status, in all cases you **must** follow those instructions for aircraft **without** this modification OSB 315-66.

The following important tables are reproduced *verbatim* from the POH

Page 2.3A - Limiting airspeeds

	Description	Knots	Note
Vne	Never exceed speed in calm air	135 135 130 115 103	0ft - 6562ft 6563ft - 9842ft 9843ft - 16404ft 16405ft - 22966ft 22967ft - 29528ft
Vra	Max. permissible speed in heavy turbulence	92	Never exceed this speed in heavy turbulence. There is heavy turbulence in lee-waves, cumulonimbus etc.
Va	Design manoeuvring speed	92	Do not make abrupt control movements above this speed. This might overload the structure.
Vw	Max. winch launch speed	76	Do not exceed this speed during winch or autotow launching
Vt	Max. aerotowing speed	92	Do not exceed this speed during aerotowing

Page 2.4A - ASI markings

Marking	Knots	Note
Green arc	43 - 100	Normal operating range (lower limit 1.1 Vs at max. weight and most forward C of G position. Upper limit reduced with MSB 315-65, refer to yellow line)
Yellow arc	100 - 151	Invalid with MSB 315-65. Refer to red and yellow line.
Yellow line	92	Limitation of the speed in turbulence according to MSB 315-65 Above this speed up to Vne is not permitted to fly in turbulence and manoeuvres must be conducted with caution
Red line	135	Maximum speed for all operations (limited with MSB 315-65)
Yellow triangle	52	Approach speed at max. weight

S/N 34197



BURKHART GROB
LUFT-UND RAUMFAHRT GmbH & Co. KG
8939 Mattsies

PILOT'S OPERATING HANDBOOK

Model : GROB G 103 C "TWIN III ACRO"
Serial No. :
Registration No. :

Date of Issue: January 1989

Pages identified by "LBA approved" are approved by

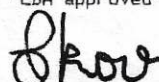
SKOV  (Signature)
LUFTFAHRT-BUNDESAMT (Authority)



(Stamp)

26. Mai 1989 (Original Date of Approval)

This sailplane is to be operated in compliance with information and limitations contained herein.





Approval of translation has been done by best knowledge and judgement. In any case the original text in German language is authoritative.

0.1 Record of Revisions

Any revision of the present manual, except actual weighing data, must be recorded in the following table and in any case of approved Sections endorsed by the responsible airworthiness authority.

The new or amended text will be indicated on the revised page by a black vertical line in the right hand margin, and the Revision No. and the date will be shown on the bottom left hand corner of the page.

Current State of Revision:

Rev. No.	Affected Section	Affected Pages	Date	Reference	Date of Approval	Date Inserted	Signature
1	0 2 3 4 6	0.3,0.4,0.5 2.3,2.5, 2.11,2.12 3.3 4.3,4.15 6.4	18 July 1989	TM 315-40	Sept. 8/89 		
2	0 2 3 4	0.3,0.4 2.7,2.8 3.6 4.15,4.21	23 Nov. 1989	TM 315-42	Nov. 24 /89 		
3	0 1 4 7	0.1,0.3,0.4 0.5 1.5 4.6,4.15 7.7	08 May 1992	AM 315-18	03.06.92 		
4	0 9	0.3,0.6 9.1,9.2,9.3	14 Jan. 1993	TM 315-52/ TM 315-53	Feb. 11, 93 		

Current State of Revisions

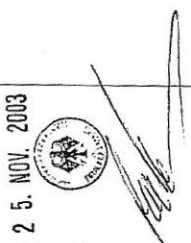
Rev. No.	Affected Section	Affected Pages	Date	Reference	Date of Approval	Date inserted	Signature
5	0 2 4	0.2A, 0.3, 0.4, 2.3, 2.4, 2.6, 2.7, 2.8, 2.9, 2.11, 4.11, 4.14, 4.16, pages 4.18 to 4.31 are deleted	15.09.2003	MSB 315-65			
6	0 2 4	0.2A, 0.3, 0.4, 2.3, 2.3A, 2.4, 2.4A, 2.6, 2.7, 2.8, 2.9, 2.11, 4.11, 4.14, 4.16, 4.18, 4.19, 4.20, 4.21, 4.22, 4.23, 4.24, 4.25, 4.26, 4.27, 4.28, 2.29, 4.30, 4.31	16.10.2003	OSB 315-66	2 5. NOV. 2003 		

0.2 List of Pages

Paragraph	Page	Date	Reference
0	Front page		
	0.1	08.05.92	
	0.2		
	0.2A	16.10.03	OSB 315-66
	0.3	16.10.03	OSB 315-66
	0.4	16.10.03	OSB 315-66
	0.5	08.05.92	
	0.6	14.01.93	
	0.7	Jan. 89	
1			
	1.1	Jan. 89	
	1.2	Jan. 89	
	1.3	Jan. 89	
	1.4	Jan. 89	
	1.5	08.05.92	
	1.6	Jan. 89	
2			
	2.1	Jan. 89	
	2.2	Jan. 89	
	2.3 LBA approved	16.10.03	OSB 315-66
	2.3A LBA approved	16.10.03	OSB 315-66
	2.4 LBA approved	16.10.03	OSB 315-66
	2.4A LBA approved	16.10.03	OSB 315-66
	2.5 LBA approved	Jan. 89	
	2.6 LBA approved	16.10.03	OSB 315-66
	2.7 LBA approved	16.10.03	OSB 315-66
	2.8 LBA approved	16.10.03	OSB 315-66
	2.9 LBA approved	16.10.03	OSB 315-66
	2.10 LBA approved	Jan. 89	
	2.11 LBA approved	16.10.03	OSB 315-66
	2.12 LBA approved	18.07.89	

Paragraph	Page	Date	Reference
3	3.1	Jan. 89	
	3.2	Jan. 89	
	3.3 LBA approved	Jan. 89	
	3.4 LBA approved	Jan. 89	
	3.5 LBA approved	Jan. 89	
	3.6 LBA approved	23.11.89	
	3.7 LBA approved	Jan. 89	
	3.8 LBA approved	Jan. 89	
4	4.1	Jan. 89	
	4.2	Jan. 89	
	4.3 LBA approved	Jan. 89	
	4.4 LBA approved	Jan. 89	
	4.5 LBA approved	Jan. 89	
	4.6 LBA approved	08.05.92	
	4.7 LBA approved	Jan. 89	
	4.8 LBA approved	Jan. 89	
	4.9 LBA approved	Jan. 89	
	4.10 LBA approved	Jan. 89	
	4.11 LBA approved	16.10.03	OSB 315-66
	4.12 LBA approved	Jan. 89	
	4.13 LBA approved	Jan. 89	
	4.14 LBA approved	16.10.03	OSB 315-66
	4.15 LBA approved	08.05.92	
	4.16 LBA approved	16.10.03	OSB 315-66
	4.17 LBA approved	Jan. 89	
	4.18 LBA approved	16.10.03	OSB 315-66
	4.19 LBA approved	16.10.03	OSB 315-66
	4.20 LBA approved	16.10.03	OSB 315-66
	4.21 LBA approved	16.10.03	OSB 315-66
	4.22 LBA approved	16.10.03	OSB 315-66
	4.23 LBA approved	16.10.03	OSB 315-66
4.24 LBA approved	16.10.03	OSB 315-66	
4.25 LBA approved	16.10.03	OSB 315-66	
4.26 LBA approved	16.10.03	OSB 315-66	
4.27 LBA approved	16.10.03	OSB 315-66	
4.28 LBA approved	16.10.03	OSB 315-66	
4.29 LBA approved	16.10.03	OSB 315-66	
4.30 LBA approved	16.10.03	OSB 315-66	
4.31 LBA approved	16.10.03	OSB 315-66	

G 103 C TWIN III ACRO

PILOT'S OPERATING HANDBOOK

Paragraph	Page	Date	Reference
5	5.1	Jan. 89	
	5.2	Jan. 89	
	5.3	LBA approved	Jan. 89
	5.4	LBA approved	Jan. 89
	5.5	LBA approved	Jan. 89
	5.6	Jan. 89	
	5.7	Jan. 89	
	5.8	Jan. 89	
6	6.1	Jan. 89	
	6.2	Jan. 89	
	6.3	Jan. 89	
	6.4	18.07.89	
	6.5	Jan. 89	
7	7.1	Jan. 89	
	7.2	Jan. 89	
	7.3	Jan. 89	
	7.4	Jan. 89	
	7.5	Jan. 89	
	7.6	Jan. 89	
	7.7	08.05.92	ÄM 315-18
	7.8	Jan. 89	
	7.9	Jan. 89	
	7.10	Jan. 89	
	7.11	Jan. 89	
	7.12	Jan. 89	

G 103 C TWIN III ACE

PILOT'S OPERATING HANDBOOK

Paragraph	Page	Date	Reference
8	8.1	Jan. 89	
	8.2	Jan. 89	
	8.3	Jan. 89	
	8.4	Jan. 89	
	8.5	Jan. 89	
	8.6	Jan. 89	
	8.7	Jan. 89	
	8.8	Jan. 89	
	8.9	Jan. 89	
9	9.1	Jan. 89	
	9.2	14.01.93	TM 315-52/315-53
	9.3	14.01.93	TM 315-52/315-53

=====

B 103 C TWIN III AERO

=====

PILOT'S OPERATING HANDBOOK

=====

0.3 Table of Contents

	Section
General (section not subject to approval)	1
Limitations (approved section)	2
Emergency Procedures (approved section)	3
Normal Procedures (approved section)	4
Performance (containing partly approved and partly not subject to approval sections)	5
Weight and Balance (section not subject to approval)	6
Sailplane and Systems Description (section not subject to approval)	7
Sailplane Handling, Care and Maintenance (section not subject to approval)	8
Supplements	9

=====

B 103 C TWIN III ACRO

=====

PILOT'S OPERATING HANDBOOK

=====

SECTION 1

- 1. General
 - 1.1 Introduction
 - 1.2 Certification Basis
 - 1.3 Warnings, Cautions and Notes
 - 1.4 Descriptive Data
 - 1.5 Three-View Drawing

=====

G 103 C TWIN III ACRO

=====

PILOT'S OPERATING HANDBOOK

=====

1.1 Introduction

The Pilot's Operating Handbook has been designed to give all necessary information to pilots and instructors for safe and correct operation to give maximum performance of the GROB G 103 C TWIN III ACRO glider.

This handbook does include not only all data that must be furnished to the pilot according to design regulation LFSM but also supplemental data and considerations for operation, the manufacturer thinks to be of benefit to the pilot.

=====

G 103 C TWIN III ACRO

=====

PILOT'S OPERATING HANDBOOK

=====

1.2 Certification Basis

The GROB G 103 C TWIN III ACRO has been certificated by the Luftfahrt-Bundesamt in accordance with LFSM (Airworthiness Requirements for Gliders and Powered Gliders), Date of Issue October 1975.

Type Certification Sheet No. 04.315 was granted on May 26, 1989. The Airworthiness Category is "Acrobatic".

=====

B 103 C TWIN III ACRO

PILOT'S OPERATING HANDBOOK

=====

1.3 Warnings, Cautions and Notes

Statements in this handbook which are essential with regard to flight safety or handling are high lighted in the following manner:

"Warning"

means that the non-observation of the corresponding procedure leads to an immediate or important degradation of the flight safety.

"Caution"

means that the non-observation of the corresponding procedure leads to a minor or to a more or less long term degradation of the flight safety.

"Note"

draws the attention on any special item not directly related to safety but which is important or unusual.

1.4 Descriptive Data

The GROB G 103 C "TWIN III ACRO" is a two-seater mid-wing glider with a damped T-type tail. State-of-the-Art technology is used to manufacture the glider in industrial FRP construction. It is used for instruction, training, performance and aerobatic flights.

The 2-section wing is triple tapered with airbrakes (Type GROB) on the upper side.

The two seats are in tandem arrangement. The two canopies are independent of each other and open to the right.

The main wheel of the non-retractable tandem landing gear is equipped with a hydraulic disk brake. The nose wheel is steerable (standard as of S/N 34171).

Technical Data:

Wing span	18.0	m	(59.06 ft)
Length	8.18	m	(26.84 ft)
Height	1.55	m	(5.09 ft)
Wing aspect ratio	18.5		
Wing area	17.5	m ²	(188.4 sq.ft)
Max. flight weight	600.0	kg	(1322.8 lbs)
Max. wing loading	34.3	kg/m ²	(7.03 lb./sq.ft)

=====

G 103 C TWIN III ACRO

=====

PILOT'S OPERATING HANDBOOK

=====

1.5 Three-View Drawing

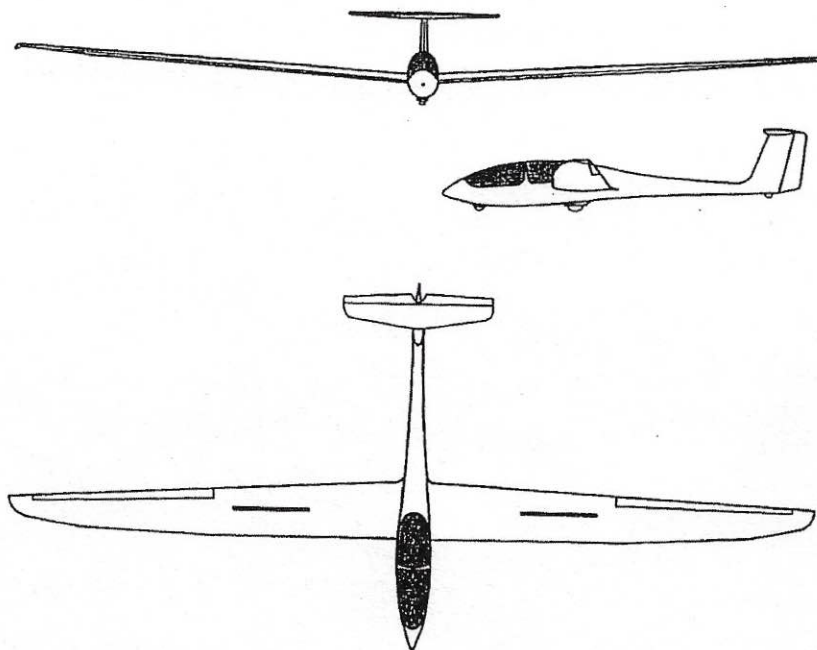

SECTION 2

- 2. Limitations
 - 2.1 Introduction
 - 2.2 Airspeed
 - 2.3 Instrument Markings
 - 2.4 - reserved -
 - 2.5 - reserved -
 - 2.6 Weight
 - 2.7 Centre of Gravity
 - 2.8 Approved Manoeuvres
 - 2.9 Manoeuvring Load Factors
 - 2.10 Flight Crew
 - 2.11 Kinds of Operation
 - 2.12 Minimum Equipment
 - 2.13 - reserved -
 - 2.14 Aerotow and Winch- and Autotow-Launching
 - 2.15 Other Limitations
 - 2.16 Limitations Placards

=====

G 103 C TWIN III ACRO

=====

PILOT'S OPERATING HANDBOOK

=====

2.1 Introduction

This section includes operating limitations, instrument markings, and basic placards necessary for safe operation of the GROB G 103 C TWIN III ACRO, its systems and the equipment installed by the manufacturer.

The limitations included in this section and in Section 9 have been approved by the Luftfahrt-Bundesamt.

2.2 Airspeed

The following table indicates the airspeed limitations and their operational guide:

CAUTION: If the fuselage reinforcement according to OSB 315-66 is installed, the following speed limits are valid:

	Speed	IAS (km/h)	(kts)	Note
V _{NE}	Never exceed speed in calm air	280 265 240 215 190	151 143 130 115 103	Never exceed this speed. Max. control deflection 1/3. 0 - 2000 m - 6562 ft - 3000 m - 9842 ft - 5000 m - 16404 ft - 7000 m - 22966 ft - 9000 m - 29528 ft altitude
V _{RA}	Max. permissible speed in heavy turbulence	200	108	Never exceed this speed in heavy turbulence. There is heavy turbulence in lee-waves, cumulonimbus etc.
V _A	Design manoeuvring speed	185	100	Do not make abrupt control movements above this speed. This might overload the structure.
V _W	Max. winch launch speed	140	76	Do not exceed this speed during winch- or autotow-launching.
V _T	Max. aerotowing speed	185	185	Do not exceed this speed during aerotowing

CAUTION: If the fuselage reinforcement according to OSB 315-66 is not installed, the following speed limits are valid:

	Speed	IAS (km/h)	(kts)	Note
V _{NE}	Never exceed speed in calm air	250 250 240 215 190	135 135 130 115 103	Never exceed this speed. Max. control deflection 1/3. 0 - 2000 m - 6562 ft - 3000 m - 9842 ft - 5000 m - 16404 ft - 7000 m - 22966 ft - 9000 m - 29528 ft altitude
V _{RA}	Max. permissible speed in heavy turbulence	170	92	Never exceed this speed in heavy turbulence. There is heavy turbulence in lee-waves, cumulonimbus etc.
V _A	Design manoeuvring speed	170	92	Do not make abrupt control movements above this speed. This might overload the structure.
V _W	Max. winch launch speed	140	76	Do not exceed this speed during winch- or autotow-launching.
V _T	Max. aerotowing speed	170	92	Do not exceed this speed during aerotowing

2.3. Instrument Markings

- Airspeed Indicator

The following table shows the airspeed indicator markings and colour code identification:

CAUTION: If the fuselage reinforcement according to OSB 315-66 is installed, the following airspeed indicator markings are valid:

Marking	IAS (km/h)	(kts)	Indicates
Green arc	79 – 185	43 - 100	Normal operating range (lower limit $1,1 v_{S1}$ at max. weight and most forward C of G position and upper limit v_A)
Yellow arc	185 – 280	100 – 151	Manoeuvres must be conducted with caution and only in calm air.
Red line	280	151	Maximum speed for all operations
Yellow triangle	96	52	Approach speed at max. weight

- Acceleration Indicator

Red radial lines at $n = + 6,5$ and $n = - 4,0$.

CAUTION: If the fuselage reinforcement according to OSB 315-66 is **not installed**, the following airspeed indicator markings are valid:

Marking	IAS (km/h)	(kts)	Indicates
Green arc	79 – 185	43 - 100	Normal operating range (lower limit 1,1 v_{S1} at max. weight and most forward C of G position. Upper limit reduced with MSB 315-65, refer to yellow line).
Yellow arc	185 – 280	100 – 151	Invalid with MSB 315-65. Refer to red and yellow line.
Yellow line	170	92	Limitation of the speed in turbulence according to MSB 315-65. Above this speed up to v_{NE} it is not permitted to fly in turbulence and manoeuvres must be conducted with caution.
Red line	250	135	Maximum speed for all operations (limited with MSB 315-65)
Yellow triangle	96	52	Approach speed at max. weight

- **Acceleration Indicator**

Red radial lines at $n = + 6,5$ and $n = - 4,0$.

=====

G 103 C TWIN III ACRO

=====

PILOT'S OPERATING HANDBOOK

=====

2.6 Weight

Max. permissible take-off mass:	600 kg	(1322.8 lbs)
Max. permissible landing mass:	600 kg	(1322.8 lbs)
Max. permissible mass of all non-lifting parts:	420 kg	(925.9 lbs)
Max. mass in baggage compartment:	10 kg	(22.0 lbs)

2.7 Centre of Gravity

CoG position range during flight

max. forward position:	270 mm (10.63 in.)	aft of datum
max. aft position:	480 mm (18.90 in.)	aft of datum

Datum (BE): Wing leading edge at the root rib

Aircraft attitude: Wedge 600:24 horizontally on upper side
of fuselage in front of vertical fin

The flight weight CoG positions have to be strictly adhered to.

The permissible CoG range is not exceeded if the loading corresponds to the loading limitations according to POH, Sec. 6.2, page 6.5 .

A lack of weight in the pilot's seat shall be compensated by ballast (see POH Sec. 6.2, page 6.4).

For determination of the empty weight CoG position see Maintenance Manual, Section 7.

2.8 Approved manoeuvres

The glider has been certified for the following aerobatic manoeuvres according to airworthiness category "Acrobatic".

CAUTION: If the fuselage reinforcement according to OSB 315-66 is installed, the following manoeuvres are approved:

- Positive loop
- Turn
- Lazy Eight
- Chandelle
- Spin
- Slow roll
- Immelmann Turn
- Split S
- Inverted flight
- Inverted spin

CAUTION: The description of these aerobatic manoeuvres and the recommended entry speeds have been provided under Sec. 4.5.9 of the Pilot's Operating Handbook.

2.9. Manoeuvring load factors

The following manoeuvring load factors must not be exceeded:

at v_A (170 km/h 92 kts)	at v_A (185 km/h/ 100 kts, if the fuselage reinforcement according to OSB 315-66 is installed)
Max. positive load factor	$n = +6,5$
Max. negative load factor	$n = -4,0$

With increasing speed the above values decrease as follows:

at v_{NE} (250 km/h/ 135 kts)	at v_{NE} (280 km/h 151 kts, if the fuselage reinforcement according to OSB 315-66 is installed)
Max. positive load factor	$n = +5,3$
Max. negative load factor	$n = -3,0$

The above manoeuvring load factors are valid for operation with retracted airbrakes.

Max. manoeuvring load factor with airbrakes extended:

at v_{NE} $n = +3,5$

2.10 Flight Crew

On solo flights the pilot has to be in the front seat.

Min. load in the 1 st seat	70 kg (154 lbs)
Max. load in the 1 st seat	110 kg (242 lbs)
Max. load in the 2 nd seat	110 kg (242 lbs)

A pilot's weight in the front seat of less than 70 kg (154 lbs) must be compensated by ballast. A pilot's weight between 55 and 60 kg (121 – 152 lbs) can be compensated by lead trim weights to be mounted in the supporting device (standard equipment) in front of the control stick frame.

2.11 Kinds of operation

With the minimum equipment prescribed (see POH Sec. 2.12, page 2.8) the glider is certified for :

- (Day) VFR flights

CAUTION: Aerobatic flights and flights in clouds are only approved if the fuselage reinforcement according to OSB 315-66 is installed.

- Aerobatic Flights
(Positive loop, turn, lazy eight, chandelle, spin, slow roll, Immelmann turn, Split S, inverted flight, inverted spin)
- Flights in clouds (if permitted by national regulations)

2.12 Minimum Equipment

- 2 airspeed indicators up to 300 km/h (162 kts) with colour codings according to POH section 2.3
- 2 altimeters
- 1 G-meter with trailing pointer (front panel)
- 2 symmetrical safety belts (each consisting of 5 parts)
- 2 sets of pedal loops
- back cushions with a min. thickness of 7 cm (2.77 in.) under load or manually or automatically parachutes for each occupant

additional equipment for cloud flights

CAUTION: Cloud flights are only approved if the fuselage reinforcement according to OSB 315-66 is installed.

- 2 vertical speed indicators
- 1 turn-and-bank indicator
- 1 magneto compass (compensated with the aircraft)
- 1 VHF transceiver* (ready for operation)

* operational equipment

Instruments and other devices of the minimum equipment shall correspond to a certified design.

Instruments and other devices of the minimum equipment shall correspond to a certified design.

2.14 Aerotow and Winch- and Autotow - Launching

Aerotow

Max. permissible speed:	170 km/h (92 kts) 185 km/h (100 kts) (if the reinforcement according to OSB 315-66 is installed)
Towing cable weak link:	max. 845 daN
Min. length of cable :	40 m (131 ft)

Winch - Launching

Max. permissible speed:	140 km/h (76 kts)
Towing cable weak link:	max. 845 daN

WARNING: The towing cable weak link must not exceed 845 daN (including tolerance).

=====

G 103 C TWIN III ACRO

=====

PILOT'S OPERATING HANDBOOK

=====

2.15 Other Limitations

2.15.1 Restrictions of the Aerobatic Certification

Gliders of the specific type are only certificated for aerobatic manoeuvres and the possible combinations thereof according to Section 2.8 and their descriptions under Section 4.5.9.

2.15.2 Loading of Baggage Compartment

Put only smooth, light objects into the compartment which can neither hinder nor injure the pilot during negative accelerations or in case of crash.

There shall be no baggage in the compartment (no canopy cover etc.) during aerobatic flights.

2.16 Limitation placards

Maximum Flying Weight	600 kp	1323 lbs			
Maximum airspeeds			km/h	kts	mph
In calm air:	V_{NE}	250	135	155	
In Rough Air:	V_{RA}	170	92	105	
Aerotow:	V_T	170	92	105	
Winch/ Automobile tow:	V_W	140	76	87	
Airbrakes extended:	V_{FE}	250	135	155	
Manoeuvring speed:	V_A	170	92	105	

Right side wall of front and rear cockpit

If the fuselage reinforcement according to OSB 315-66 is installed:

Maximum Flying Weight	600 kp	1323 lbs			
Maximum airspeeds			km/h	kts	mph
In calm air:	V_{NE}	280	151	174	
In Rough Air:	V_{RA}	200	108	124	
Aerotow:	V_T	185	100	115	
Winch/ Automobile tow:	V_W	140	76	87	
Airbrakes extended:	V_{FE}	280	151	174	
Manoeuvring speed:	V_A	185	100	115	

Towing cable weak link	
Aero-, winch and	max. 845 daN
Automobile tow:	max. 1863 lbs

Tire pressure	
Mainwheel:	36-39.8 psi 2,5 – 2,8 bar
Nose-and tail wheel:	36 psi 2,5 bar

Right side wall of front cockpit

Payload (Pilot and Parachute)	

Minimum in front cockpit: 70 kg 154 lbs	
for all flight	
(Less weight must be compensated with Trim Weights)	
Maximum load front: 110 kg 242 lbs	
(The maximum weight must not be exceeded)	

Right side wall of front and rear cockpit

=====

G 103 C TWIN III ACRO

=====

PILOT'S OPERATING HANDBOOK

=====

Limitations Placards (continued)

Max. baggage: 10 kg (22 lbs)
No baggage permitted during acrobatics

Right side wall
above baggage
compartment floor

Tire Pressure 2.5 - 2.8 bar
(36 - 39.8 PSI)

Main wheel fairing

Tire Pressure
36 PSI 2.5 bar

Nose and tail wheel

Note: Further placards are listed in the Maintenance Manual.

=====

G 103 C TWIN III ACRO

=====

PILOT'S OPERATING HANDBOOK

=====

SECTION 3

- 3. Emergency Procedures
 - 3.1 Introduction
 - 3.2 Canopy Jettison
 - 3.3 Emergency Exit
 - 3.4 Stall Recovery
 - 3.5 Spin Recovery
 - 3.6 Spiral Dive Recovery
 - 3.7 - reserved -
 - 3.8 - reserved -
 - 3.9 Other Emergencies

=====

B 103 C TWIN III ACRO

=====

PILOT'S OPERATING HANDBOOK

=====

3.1 Introduction

This section comprises

- check lists which show the recommended emergency procedures (catchwords)
- a detailed description of the emergency procedures

Emergency Procedures (Check List)

- (1) Canopy Jettison
 - Pull red handles on the right and left side backward
 - Push the canopy up

- (2) Emergency Exit
 - Release safety harness
 - Stand up and get out over left or right side depending on the attitude
 - When using a manual parachute grip release and pull firmly to full extent after 1-3 seconds

- (3) Spin (Normal Attitude)
 - Rudder control against spin direction
 - Push elevator control slightly
 - Aileron control in neutral position or against spin direction
 - After spin has been terminated rudder control in neutral position. Pull-out smoothly

- (4) Spin (Inverted Attitude)
 - Rudder control against spin direction
 - Pull elevator control
 - Aileron control in neutral position
 - After spin has been terminated rudder control in neutral position and positive pull-out

3.2 Canopy Jettison

Pull the red levers on the right side (cockpit wall) and on the left side (canopy frame) backward to the stop and push the canopy up. The airflow will release the canopies. The snap hooks of the canopy attachment open by bending and the lower attaching balls of the gas springs are torn out thus separating the canopies from the aircraft.

Warning: Do not use "more stable" snap hooks or safety pins with the gas springs. If the canopies or parts of them remain on the aircraft during emergency then the exit will be endangered.

3.3 Emergency Exit

If an emergency exit is unavoidable first release the canopies.

The roomy cockpit and its excellent fairing assist in a quick and safe exit in case of emergency. Use the rigid canopy frames of the fuselage as levers to draw yourself up and out of the cockpit.

If possible, push yourself off vigorously from the glider while jumping out.

! Attention: Wing leading edge and tail unit !

3.4 Stall Recovery

During normal and circle flight, stall is always terminated by pushing the elevator control slightly.

During circle flight, use aileron and rudder control against spin direction, as necessary.

The loss of altitude at sea level is appr. 50 m (164 ft). With increasing altitude the losses will also increase, the max. loss of altitude will be in lee wave areas at high altitudes (mountain flights).

Caution: Increased vibrations and weak controls are stall characteristics.

=====

G 103 C TWIN III ACRO

=====

PILOT'S OPERATING HANDBOOK

=====

3.5 Spin Recovery

- Normal Attitude

Safe termination of spin is made as follows:

- a) Rudder control against spin direction (full deflection)
- b) Push elevator control
- c) Aileron control to neutral position or against spin direction
- d) After termination of spin, rudder and aileron control in neutral position and pull-out smoothly from diving.

The loss of altitude from terminating the spin to the bottom point of the pull-out is appr. 280 m (920 ft) (at sea level). Pull-out speed is appr. 190 km/h (103 kts), the manoeuvring load factor appr. + 3.5 g.

Note: At forward CoG positions, it is not possible to stationarily spin the glider. After appr. 1/2 revolution, it is moving into a spiral dive.

Caution: Spinning can be avoided safely by taking the countermeasures for "Termination of Stall".

- Inverted Attitude

Safe termination of spin is made as follows:

- a) Rudder control against spin direction (full deflection)
- b) Pull elevator control
- c) Aileron control into neutral position
- d) After termination of spin, rudder and aileron control into neutral position and smooth pull-out from inverted dive.

The loss of altitude from terminating the spin to the bottom point of the pull-out is appr. 250 m (820 ft) (at sea level). Pull-out speed is appr. 210 km/h (113 kts), the manoeuvring load factor appr. + 3.5 g.

3.6 Spiral Dive Recovery

Normal Attitude

Depending on aileron and rudder control position during spin at forward CoG positions (i.e. within the range of non-stationary spinning of the GROB G 103 C TWIN III ACRO), there will be a spiral dive or yawing condition similar to the spiral dive after appr. 1/2 rotation. Both conditions are indicated by a rapid increase in speed and acceleration.

Both flight conditions are terminated as follows:

- Rudder control against spin direction
- Aileron control against spin direction
- Pull elevator control, never exceed permissible manoeuvring load factors

The loss of altitude for recovery is dependent on speed and may be up to appr. 100 m (328 ft) (at sea level). The manoeuvring load factor is + 3.5 g.

Inverted Attitude

Depending on aileron and rudder control position during spin at forward CoG positions (i.e. within the range of non-stationary spinning of the GROB G 103 C TWIN III ACRO), there will be an inverted spiral dive or a yawing condition similar to the inverted spiral dive after appr. 1/2 rotation. Both conditions are indicated by a rapid increase in speed and negative acceleration.

Both flight conditions are terminated as follows:

- Rudder control against spin direction
- Aileron control against spin direction
- Pull elevator control, never exceed permissible manoeuvring load factors

The loss of altitude for recovery is dependent on speed and may be up to appr. 150 m (492 ft) (at sea level). The manoeuvring load factor is + 3.5 g.

3.9 Other Emergencies

3.9.1 One aileron not connected

- Flight speed up to max. 120 km/h (65 kts)
- Turn at low bank
- Prepare for longer final approach than usual

3.9.2 One airbrake not connected

An airbrake that is not connected but locked will usually become obvious to the pilot on final approach only. This single-acting moment, being induced by the connected and operated airbrake, can be compensated by aileron and rudder control.

An airbrake that is not connected and unlocked will usually extend abruptly during take-off. A rudder control deflection of appr. 60 % will prevent a single-acting yawing.

- Either launching or towing should be continued until safe altitude is reached.
- Max. airspeed 150 km/h (81 kts)

With one airbrake extended, a side slip at low bank is possible in either direction.

3.9.3 Ground Looping

If the remaining distance between touch-down point and end of field is too short a decision in favour of a controlled ground looping at least 30 m (98 ft) before the end of the landing field should be taken.

- If possible, turn into the wind
- Simultaneous aileron and rudder control deflections into turn direction with control stick fully pulled and wheel brake released.

Ground looping requires the release of the nose wheel which is only possible with released brake and sufficient elevator control efficiency (more than 40 km/h / 22 kts).

=====

G 103 C TWIN III ACRO

=====

PILOT'S OPERATING HANDBOOK

=====

3.9.4 Emergency Landing on Water

From experience with emergency landings of FRP powered gliders on water, one can expect the following: gliders with fixed or extended landing gear, touching down at minimum speed (with the airbrakes retracted) and almost at zero rate of descent, do not tend to "dive down". FRP aircraft are capable of floating for a certain period of time.

Warning: An emergency landing on water, however, shall always be the last resort only!

SECTION 4

- 4. Normal Procedures
 - 4.1 Introduction
 - 4.2 Rigging and De-rigging
 - 4.3 Daily Inspection
 - 4.4 Preflight Inspection
 - 4.5 Normal Procedures and Recommended Speeds
 - 4.5.1 Launching Techniques
 - 4.5.2 – reserved –
 - 4.5.3 Cruise and Cross-Country Flight
 - 4.5.4 Approach
 - 4.5.5 Landing
 - 4.5.6 – reserved –
 - 4.5.7 High Altitude Flight
 - 4.5.8 Flight in Rain
 - 4.5.9 Aerobatics
 - 4.5.10 Flights in Clouds

CAUTION: Aerobatics according to 4.5.9 and flights in clouds according to 4.5.10 are only approved if the fuselage reinforcement according to OSB 315-66 is installed.

=====

G 103 C TWIN III ACRO

=====

PILOT'S OPERATING HANDBOOK

=====

4.1 Introduction

This section covers check lists for the daily inspection and the preflight check. In particular, the junctions in the control system (assembly and inspection) have been described in detail.

Furthermore, this section includes a description of the normal operating procedures and the recommended speeds.

Normal procedures relating to additional equipment will be described in Section 9.

4.2 Rigging and De-Rigging

- Rigging

For rigging, hold the fuselage tight in a horizontal position. We recommend to use a fuselage horse or the assembly undercarriage (trailer equipment).

Assembly of the glider can be conducted by 3 or 4 persons as follows:

- Open the 4 sliding sleeves inside the fuselage
- Release the airbrakes in the wings
- Insert the right wing into the fuselage
- Turn the sliding sleeves (right side) so that the guide pins engage in the shaft guides of the sleeves. By slightly moving the wing, the sliding sleeves will snap into place with a distinctly audible sound.
- Insert the left wing into the fuselage and arrange the two spar stub bolts by moving the wing tips up and down so that they will enter the corresponding bearings of the root ribs. Move the wing tips circularly to insert the wing bolts into the wing connecting tube. It is advisable to unload the root rib forward and rear.
- Turn the sliding sleeves (left side) so that they snap into place by moving the wing fore and aft.
- Turn the knurled nuts (1) of the wing connecting tubes into the sliding sleeves (2) so that they are drawn against the red rings which are held by the guide pins (3) = protective device.
By means of moving the wing tips fore and aft, the knurled nuts can be secured tight (4) while securing the guide pins however, must not strike against the end of the milled selector of the shaft guide.

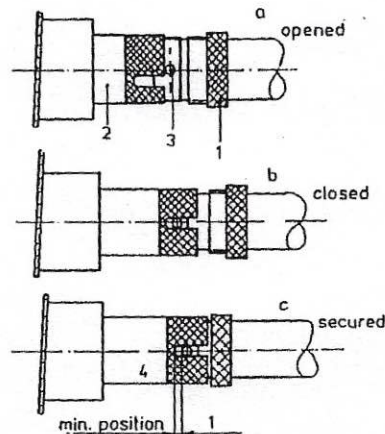

Inspection: The red rings at the fuselage tubes shall be concealed by the sliding sleeves, the knurled nuts shall be tightened hard.

In a closed but not secured position (b), the wing bolt cannot be removed from the locking.

- Connection of ailerons and airbrakes

The short connecting rods inside the fuselage are equipped with quick-locks which have to be coupled with the joints of the wing push rods.

Inspection: The quick-lock slide shall protrude so that the safety pin is snapped into place. After the quick-locks have snapped into place, try to push the safety pin backward without pressing it down. If you do not succeed the controls have been linked properly.

=====

G 103 C TWIN III ACRO

=====

PILOT'S OPERATING HANDBOOK

=====

Horizontal Tail

- Before mounting the horizontal tail, hinge down the leading-edge flap and pull out the butterfly nut up to the stop limit. See that the large opening of the cone-shaped bearings of the horizontal tail spar shows to the rear.
- Mount the horizontal tail so that the automatic elevator joint engages.
- Push the elevator fin rearwards onto the 3 bolts
- Screw the butterfly nut tight.

Correct assembly can be checked when the butterfly nut is so tight that the horizontal tail is free from play in any direction. The horizontal tail shall be secured by mounting the leading edge flap with the butterfly screw in horizontal position. If necessary, tighten or release it by 1/4 turn.

Note: Tighten the butterfly screw manually only, do not use any tool.

Inspection after Rigging

- Check the 4 slide sleeves inside the fuselage are secured
- Check correct setting of the aileron and airbrake quick-locks, as being described above
- Check operating force and functioning of the towing hooks
- Check functioning of the wheel brake and tire pressure
- Check tight fit of horizontal tail
- Check controls with the help of a second person

After the glider is inspected, adhesive tape should be added to the wing-fuselage and the fuselage-horizontal tail joints.

Note: Always add adhesive tape to the horizontal tail joint to avoid airflow separations at the fitting holes of the horizontal tail which may result in slight control stick vibrations.

De-Rigging

De-rigging is achieved in reverse order thus making no difference which wing is removed first.

If the glider is parked outside with the horizontal stabilizer removed, the elevator control rod in the vertical fin must be covered properly in order to prevent the ingress of moisture.

4.3 Daily Inspection

It is essential that a full inspection is carried out after each rigging prior to readiness for takeoff and before each days flying.

Walk around the airplane

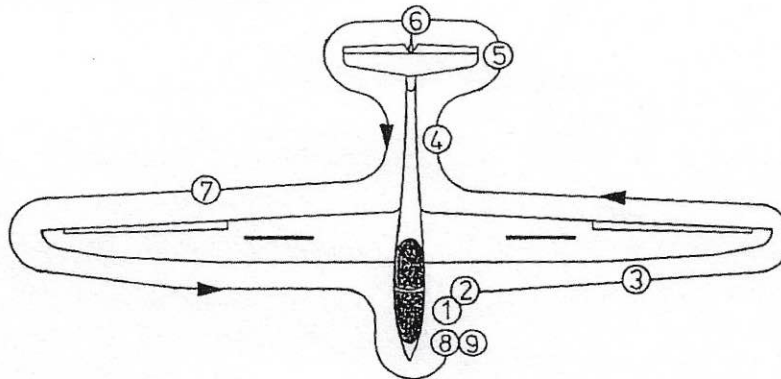

While walking around the glider, check the surface for cracks, bucklings or unevenness or any unusual feature. In case of doubt call an expert for a professional opinion.

=====

B 103 C TWIN III ACRO

PILOT'S OPERATING HANDBOOK

=====

(1) Canopies

- open canopies
- check the 4 slide sleeves inside the fuselage are secured
- visual inspection of all control installations and joints
- check controls for free motion
- check condition and functioning of the towing hooks
- check functioning of the wheel brake
- check canopy locking device and canopy emergency release
- check for foreign objects

(2) Front part of fuselage

- check fuselage shell for damages, in particular the lower side of the fuselage and the landing gear area
- check tire pressure main wheel (2.5 - 2.8 bar/36 - 39.8 PSI) and nose wheel (2.5 bar/36 PSI) and state of wheels
- check cleanliness and functioning of the towing hooks

(3) Left wing

- check upper and lower surface of the wing for damage
- visual inspection of all control installations
- aileron (check state, free motion and play)
- airbrakes (check state, fit and locking mechanism)

(4) Rear part of fuselage

- check fuselage tube and vertical fin for damages, in particular the lower surface and the tail wheel area
- check multi-probe for cleanliness and correct mounting
- check tire pressure tail wheel (2.5 bar/36 PSI)

(5) Horizontal tail

- check elevator fin for damages, correct mounting and verify it is secured properly
- elevator (check state, free motion and play)

(6) Vertical Tail

- check state, free motion and play

(7) Right wing

- see Item (3)

(8) Flying Controls Check

The flying controls check shall be undertaken by two people as follows:

One person operates the controls in the front seat while the second carefully monitoring the corresponding controls without any force. Check the controls for undue play of the control rods. After releasing the controls, check for free motion up to full deflection.

(9) Instrument Functioning Check

The instrument functioning check is undertaken by two people as follows:

One person carefully blows into the corresponding ports of the Multi-probe while the second is checking the gauges.

- Pitot port: airspeed indicators shall indicate positive values
- Static port: altimeters shall indicate negative values
- TEK port: vertical speed indicators shall indicate positive values

After rough landings or overstress during flight, the entire airplane has to be inspected very carefully with the wings and horizontal tail being disassembled. If damage is determined an authorized inspector (corresponding to the German Prüfer für Luftfahrtgerät Klasse III) shall be consulted. Do not take off again before the damage has been repaired.

4.4 Preflight Inspection

- Weight and balance checked?
- Parachutes correctly fitted?
- Safety belts on and fastened correctly?
- Pedals adjusted and/or locked?
- Airbrakes locked after functioning check?
- Free motion of controls checked?
- Controls checked with the help of a second person?
- Trim device adjusted at the green marking?
- Altimeter set?
- Radio set to airfield frequency?
- Canopies closed and locked?
- Correct safety member at the towing cable ?
- Cable correctly hooked ?
- Attention: - crosswind
 - cable break

4.5 Normal Procedures and Recommended Speeds

4.5.1 Launching Techniques

Winch Launching

- Adjust trim lever at the green marking
- Max. launching speed: 140 km/h (76 kts)
- Max. permissible crosswind component: 20 km/h (11 kts)
- Engage the cable in the winch launching hook
- Towing cable weak link: max. 845 daN

During roll and takeoff, the glider has no tendency to swing off or to pitch up. If the winch is very powerful and initial acceleration is very fast, push the control stick slightly until safe altitude is reached. Then slightly pull to achieve steep climb attitude.

Normal launching speed is appr. 115 km/h (62 kts).

Generally, the cable is automatically released after having reached the max. launching altitude. After the cable tension has decreased, pull the cable release button strongly to the backstop several times.

Caution: Before takeoff check seat position and whether the controls can be reached.
If you use a seat cushion take special care that you are not able to slide backward during takeoff or steep climb.

Warning:

- Strict attention must be given to attempting launch with tail wind conditions while using weak winches.
- Release cable immediately if the wing makes surface contact during takeoff
- Release cable immediately at swing-off angles of more than 15°

Aerotow

- Adjust trim lever at the green marking
- Max. towing speed:
 - 170 km/h (92 kts)
 - 185 km/h (100 kts)
 - (if the reinforcement according to OSB 315-66 is installed)
- Max. permissible crosswind component: 25 km/h (13 kts)
- Engage cable in the nose hook
- Towing cable weak link: max. 845 daN
- Recommended cable length: 40 – 60 m (131 – 197 ft)

If necessary, apply slight pressure to the wheel brake during takeoff so as not to overrun the towing cable. During the entire acceleration phase, the glider can be controlled with rudder and aileron, if necessary up to full deflection. At an airspeed indication of appr. 70 km/h (38 kts), the glider can become airborne.

After lift-off, climb to appr. 1 to 4 m (3 – 13 ft) to avoid ground effect wake turbulence, initiated by the tow plane.

For cable release, pull the cable release button several times to the backstop.

NOTE: The glider has no tendency to swing off during takeoff, however, if one wing makes ground contact during takeoff or at direction changes of more than 15°, release cable immediately.

WARNING: Aero tows with the cable engaged in the hook for winch launching is prohibited.

4.5.3 Cruise and Cross-Country Flight

At any speed, loading condition, configuration and CoG position, the glider has pleasant characteristics.

With the airbrakes retracted, the max. time to change from a 45° banked turn to a 45° banked turn opposite of direction is 4.5 sec.

According to the flight weight CoG position, the trim device can be set between minimum speed and appr. V_A .

Slow Flight and Stalling Characteristics

The stalling speed or minimum control speed is dependent on the loading and the condition of the glider. The following recommended values are valid:

Single-seated			Double-seated		
Flight weight	without airbrakes	with airbrakes	Flight weight	without airbrakes	with airbrakes
470 kg	62 km/h	68 km/h	600 kg	72 km/h	80 km/h
1036 lbs	33 kts	37 kts	1323 lbs	39 kts	43 kts

Stalling from Straight Flight (aft CoG position)

At aft CoG positions, there is a stall warning 3-6 km/h (2-3 kts) before reaching stall speed. There is a tail vibration which increases with continuing pull on the control stick. Aileron control becomes distinctly weaker and the glider tends to yaw, with an incorrect reaction by the pilot the glider tends to roll off over the wing if the flight attitude is inaccurate (not free from yawing and stalled).

The altitude loss to recovery (from a stalled flight attitude free from yawing) is 50 m (164 ft) (at sea level).

=====

G 103 C TWIN III ACRO

=====

PILOT'S OPERATING HANDBOOK

=====

Stalling during Circle Flight (aft CoG position)

While stalling, the glider rolls off in the direction of rudder deflection. With the rudder control in neutral position, the glider tends to slightly roll into turn direction. By slightly pushing the elevator control and aileron and rudder control against turn direction normal flight attitude will be recovered. The glider does not tend to spin uncontrollably.

When stalling free from yawing, the loss of altitude to recovery (normal flight attitude) is appr. 50 m (164 ft) (at sea level).

Stalling during Straight and Circle Flight
(forward CoG position)

The glider will stall with the control stick fully pulled back. There will be no roll-off. Normal flight attitude shall be recovered by pushing the elevator control and, if necessary, by operating the aileron and rudder control against turn direction.

The loss of altitude is 20 m (66 ft) (at sea level).

Note: Stalling from straight or turning flight:
Push control stick, rudder control against turn direction, if necessary.

High – Speed Flight

If the reinforcement according to OSB 315-66 is **not installed**:

In particular, do not exceed the max. permissible speed $V_{NE} = 250$ km/h (135 kts).

Full control deflections are only permitted up to a speed of max. 170 km/h (92 kts). At a speed of 250 km/h (135 kts) only 1/3 of control deflection is permitted.

In heavy turbulence, e.g. in lee wave rotors, cumulonimbus, visible tornados or when passing crests do not exceed the gust speed $V_{RA} = 170$ km/h (92kts).

Up to v_{NE} the flaps may be extended. However, the airbrakes should only be extended at such high speeds in emergency or when tending to exceed v_{NE} . E.g. there is danger of exceeding v_{NE} when reaching 250 km/h (135 kts) during steep dive. Extending the airbrakes during high speed flight will result in deceleration and negative load factors. Please see to it that the safety belts are well fastened and that you do not simultaneously operate the control stick while extending the airbrakes. Steep dive with extended airbrakes and max. flight weight is limited to a dive angle of 32° at 250 km/h (135 kts).

If the reinforcement according to OSB 315-66 is installed:

In particular, do not exceed the max. permissible speed $V_{NE} = 280$ km/h (151 kts).

Full control deflections are only permitted up to a speed of max. 185 km/h (100 kts). At a speed of 280 km/h (151 kts) only 1/3 of control deflection is permitted.

In heavy turbulence, e.g. in lee wave rotors, cumulonimbus, visible tornados or when passing crests do not exceed the gust speed $V_{RA} = 200$ km/h (108kts).

Up to v_{NE} the flaps may be extended. However, the airbrakes should only be extended at such high speeds in emergency or when tending to exceed v_{NE} . E.g. there is danger of exceeding v_{NE} when reaching 260 km/h (140 kts) during steep dive. Extending the airbrakes during high speed flight will result in deceleration and negative load factors. Please see to it that the safety belts are well fastened and that you do not simultaneously operate the control stick while extending the airbrakes. Steep dive with extended airbrakes and max. flight weight is limited to a dive angle of 54° at 280 km/h (151 kts).

4.5.4 Approach

With the airbrakes fully extended, the recommended normal approach speed is 96 km/h (52 kts) at a glide ratio of 1 : 6.6 in calm air. Airbrake efficiency is sufficient for steep approaches. The airbrakes induce a slight nose-down moment so that the glider almost maintains the selected speed after extending the airbrakes. The time to change from a 45° banked turn to a 45° banked turn of opposite direction is 5 sec.

- Note:** - The above recommendation is only valid for stabilized pitch attitudes.
- If approach is made at low speed and the airbrakes are only partly extended avoid a further extension of the airbrakes shortly before touch-down otherwise the glider will start dropping.

The side-slip is quite controllable and, if needed, this manoeuvre can be used for steeper approaches. It is effective by using a 15 degrees angle of sideslip; the recommended airspeed range is between 96 km/h (52 kts) and 185 km/h (100 kts).

The slip should be completed at a safe height. Rudder effect reversal has not been observed above 96 km/h (52 kts). The airspeed indication is well usable in this range and shows no unusual deviation.

4.5.5 Landing

The use of fully extended airbrakes for landing should be kept strictly for "emergency use only" to avoid causing unnecessary wear and tear of the landing gear (linkage - airbrakes - wheel brake). Touch down at a low speed, if possible, to keep the landing run as short as possible.

After touch-down of the nose wheel, direction control can be made by the rudder control down to a speed of appr. 40 km/h (22 kts) and by the nose wheel steering and rudder (standard as of S/N 34171) even down to a speed of appr. 20 km/h (11kts).

4.5.7 High Altitude Flight

For test flights for proof of flutter were made at an altitude of approx. 2000 m (6562 ft). With increasing altitude, the airspeed indicator shows a lower speed as true. However, the true airspeed is determining the flutter limits. Therefore, the following limits are valid for flights at high altitude:

Standard – Flight Altitude (m above SL)	m	ft	V _{max} IAS (km/h)	fts	V _{max} IAS (km/h)	fts
					if the fuselage reinforcement acc. to OSB 315-66 is installed	
0 – 2000	0 – 6562		250	135	280	151
- 3000	- 9843		250	135	265	143
- 5000	- 16404		240	130	240	130
- 7000	- 22966		215	116	215	116
- 9000	- 29528		190	103	190	103
- 11000	- 36089		165	89	165	89

Flights at Temperatures below Freezing Point

At temperatures below 0°C, e.g. when flying in mountain waves or in winter, it is possible that easy action of the controls may be lowered.

See to it that the controls are free from humidity to prevent the danger of icing.

This is also valid for rudder and airbrake slots. We recommend to put Vaseline onto the endangered parts to avoid any freezing.

Avoid any humidity penetrating Gel Coat cracks which might lead to breaking open the varnish at low temperatures.

=====

G 103 C TWIN III ACRO

PILOT'S OPERATING HANDBOOK

=====

4.5.8 Flight in Rain

With wet or slightly iced wings, there is no considerable deterioration of the flight characteristics.

Heavy ice or rain on the wings will increase the stalling speed by appr. 10 km/h (5 kts) thus not affecting takeoff and touch-down characteristics:

Increase approach speed by appr. 10 km/h (5 kts).

4.5.9 Aerobatics

CAUTION: Aerobatics are only approved if the fuselage reinforcement according to OSB 315-66 is installed.

Aerobatics should only be performed by those pilots with the correct licence. Excluded from this regulation are single-seated training flights of aerobatic flying students under supervision of an aerobatic flight instructor. Aerobatic flights with passengers shall only be made with the consent of the passenger.

General notes on Aerobatic Instruction

Experience from aerobatic training camps during the last few years shows clearly that double-seaters are "a must" for aerobatic training. While loops and turns can be trained on a single-seater because there are no critical attitudes initiated by mistakes, a double-seater is absolutely necessary for any flight manoeuvres which include rolls or elements of rolls. There are typical mistakes, which are always repeated, while performing a roll which may lead to too high speeds and pull-out load factors. In particular, this is deemed to be true the better the aerodynamic quality and thus the acceleration attitude of the glider.

In the initial training phase, radio contact between instructor and student (a means to be recommended in other cases) does not help very much because the student will hardly be responsive in critical situations.

It is useful to start aerobatic instruction with a thorough introduction to inverted flight with all its different phases: straight flight (direction reference point!) constant speed - intentional speed variation - change of direction - inverted circles.

The "TWIN III" is very suitable for this introduction. However, due to the high moment of inertia of the glider, some manoeuvre elements are more difficult to execute than with a single-seater. Therefore, it makes a modicum of sense to repeat the exercises single-seated on the heavy double-seater. It is worthwhile taking a more "handy" single-seater.

During Immelmann Turns and Split S manoeuvres, the glider has a tendency to spin invertedly which may or could lead to a complete inverted spin if unfavourable or incorrect control coordination is initiated.

Therefore, we recommend that qualified instruction is even given to experienced aerobatic instructors so that they may familiarize themselves with the aerobatic diversity of the G 103 C TWIN III ACRO and impart their knowledge to their students.

WARNING: The TWIN III shall not be compared to other gliders with regard to the following aerobatic manoeuvres:

- Immelmann Turn and Split S
- Slow Rolls and part of rolls
- Inverted Flights and inverted circles
- Inverted spin

We strongly recommend a thorough and qualified instruction.

- **Preparation and Termination of Aerobic Flights**

CAUTION: Aerobatics are only approved if the fuselage reinforcement according to OSB 315-66 is installed.

- **Before Flight**

Before executing aerobic manoeuvres, check maximum weight and CoG position. Any loose objects must be removed from the glider (from the side wall pockets inside the cockpit). Remove the oxygen bottle and the baggage from the baggage compartment.

- **Before commencing aerobatics**

Flight altitude: sufficient altitude for terminating the manoeuvre? No aerobic manoeuvres below 400 m (1312 ft).

Airspace: Request clearance for aerobatics in controlled airspace (which is almost everywhere due to the necessary initial altitude). Always check that there are no other aircraft in the vicinity?

Safety belts: fastened?

Canopies: locked?

Parachutes: correctly adjusted, hooked, rip cord attached?

No **loose parts** inside the aircraft, no loose parts inside the side wall pockets?

Airbrakes: retracted and locked?

Trim: neutral to "nose down"

The max. speed $v_{NE} = 280$ km/h (151 kts) must not be exceeded.

If the pilot loses control or if there is danger of exceeding v_{NE} , the airbrakes have to be operated, they may be extended up to a speed of 280 km/h (151 kts).

With the airbrakes extended, no aerobic manoeuvres can be executed. The pull-out loads with extended airbrakes must not exceed +3.5 g.

Aerobic Manoeuvres

CAUTION: Aerobatics are only approved if the fuselage reinforcement according to OSB 315-66 is installed.

- **Loop upward**

entry speed	190 - 210 km/h	(103-113 kts)
load factor	appr. 3 - 4 g	
exit speed	appr. 180 km/h	(97 kts)

In order to fly a circular loop, the control force should not be constant - but varied.

Neither control force nor control displacement provide sufficient information for executing a well-completed loop. In general, however, one can say that with decreasing speed control force has to be abated. The angular velocity is the pilot's only checking device for performing a uniform loop radius (view sideways ahead). But the angular velocity has to be reduced to the same extent as flight speed decreases.

It is important to check the horizontal bank at the bottom while pulling up and at the top during inverted position.

If the wing is not in a horizontal position it will lead to a "spiral loop".

- Turn

CAUTION: Aerobatics are only approved if the fuselage reinforcement according to OSB 315-66 is installed.

entry speed	190 km/h (103 kts)
load factor	appr. 4 - 5 g

Pull up quickly to a vertical position, then apply elevator control to neutral (check attitude over the wing). At appr. 140 km/h (76 kts), rudder control to full deflection - **slowly**, (not by jerks, operating time appr. 2 sec) thus initiating a turn of appr. 50° around the normal axis (fan!) in the vertical phase (check by elevator control!).

Slight aileron support against turn direction is necessary to avoid a turn into an inverted position. If the rudder control is operated too early or too jerkily, yawing will occur and the turn will almost stop when reaching the initial yawing angle. If the rudder control is operated too late or too cautiously fan will not be sufficient for a proper turn. In either case the glider will first slide backward and then pitch down forward or inverted.

The pilot needs some "TWIN" experience to find out if and when a turn has not been successful and will become an unintentional tail slide.

In any case, keep the rudder control at full deflection and aileron and elevator control in neutral position to avoid a reversal of the controls while tail sliding unintentionally.

- **Slow roll** (from normal to normal attitude)

CAUTION: Aerobatics are only approved if the fuselage reinforcement according to OSB 315-66 is installed.

entry speed	175 - 185 km/h	(94-100 kts)
load factor	$\pm 1,5$ g	
exit speed	160 - 185 km/h	(86 - 100 kts)

With the trim fully nose-down stabilize the speed at v_E during dive. Reduce pitch attitude slightly. Speedy operation of the aileron control, full deflection, into the desired direction (switch-over time appr. 1 sec.). High control forces, if necessary, operate the control stick with both hands. Before reaching vertical bank, operate the rudder control appr. 30% against the aileron control and maintain it.

Before reaching the inverted position, push the elevator control to avoid an inverted dive.

While pushing, the roll speed will distinctly increase (destabilization) so that an uniform rotation can be maintained by reducing the aileron deflection (appr. 50%).

Because of the aileron differentiation which has been designed for normal requirements have the rudder control smoothly deflected into the other direction only after a rotation of appr. 240° (appr. 30% "to" aileron control).

NOTE:

Please note that changing from a positive to a negative flight attitude is related to a relatively high variation of the lift coefficient (airfoil). During the transition phase, "vibrations" are resulting from an airflow separation at the down-turning outboard wing which should be avoided by reducing aileron deflection in order to perform the roll correctly. If proceeding as prescribed, the glider will steadily dive while rolling in order to maintain the speed, necessary for correct flying.

In all cases, the pilot has to avoid a rudder deflection in aileron direction while initiating a roll (which beginners may do instinctively), because the glider will then dive too steeply. In the second half of roll execution, the pilot has to see to it that he only pulls at zero-bank (or max. 20° before zero). If the pilot pulls out too early, the glider will change direction against the aileron control deflection. I.e. in a slow roll to the left, the glider will change direction to the right. Directional errors in a roll are mostly caused by incorrect elevator operation.

- **Slow Half-Roll** (from normal to inverted altitude)

CAUTION: Aerobatics are only approved if the fuselage reinforcement according to OSB 315-66 is installed.

entry speed 175 – 185 km/h (94 - 100 kts)

The slow half-roll is executed as the first half of the slow roll, described above. For beginners, it is a more favourable manoeuvre because the sum of errors possibly deriving from minor mistakes will not be so serious.

- **Slow Half-Roll** (from inverted to normal attitude)

entry speed 175 – 185 km/h (94 - 100 kts)

First stabilize the speed to v_E in the inverted position, then perform the second half of the slow roll, described above.

- **Immelmann Turn** ($\frac{1}{2}$ loop with subsequent $\frac{1}{2}$ roll)

entry speed 210 - 240 km/h (113-130 kts)
load factor 3.5-4.5 g

The first part of the manoeuvre, $\frac{1}{2}$ loop, shall be pulled up at high elevator control force so that the apex will be reached at a speed of appr. 120 - 130 km/h (65 - 70 kts). At the top of the loop (inverted position) the pilot's view is straight ahead, with regard to horizon and aircraft datum points, the pilot stops pulling when in the same attitude as in stationary inverted flight. Then the elevator control shall be operated toward the neutral position. The flight attitude can only be verified (horizon !) by flying straight for a short period of time. Operate the aileron control to full deflection in order to initiate the half-roll. For possible elevator operating errors see "Slow Roll".

NOTE:

No full control deflections at high entry speeds. Do not exceed the load factor according to Item 2.9.

- **Split S** ($\frac{1}{2}$ roll with subsequent $\frac{1}{2}$ loop positive)

CAUTION: Aerobatics are only approved if the fuselage reinforcement according to OSB 315-66 is installed.

entry speed 230 – 250 km/h (124 - 135 kts)

First stabilize the speed to v_E in a dive. Pull the glider's nose appr. 20° above the horizon. When the desired angle is reached, return elevator control to neutral position. Aileron control to the desired direction. Maintain 10° climbing flight path by means of the elevator control. At a speed of 130 - 150 km/h (70 - 81 kts), initiate the $1/2$ loop by pulling.

In order to maintain a uniform circle radius, pull first with low control force and then - with increasing speed - with an accordingly higher control force. While levelling off, the speed shall not exceed 230 km/h (124 kts).

- Inverted Flight

CAUTION: Aerobatics are only approved if the fuselage reinforcement according to OSB 315-66 is installed.

The best method to initiate the inverted position is by a half-roll. This is not because the half-roll is an important training element but because this manoeuvre (in comparison with 1/2 loop) provides more easily the correct speed for the inverted flight. The best speed for inverted flights is 160 km/h (86 kts), the minimum speed is 125 km/h (67 kts) at a flight weight of 600 kg (1323 lbs). Do not initiate inverted turning at speeds below 160 km/h (86 kts) (airflow separation at the down turning outboard wing).

Inverted flight is terminated by a half, described as a "Split S".

WARNING:

There is no warning on reaching the minimum (stall) speed during inverted flight. There are heavy vibrations during inverted stall. However, the glider remains partially controllable. In order to extricate yourself from stalling, increase the speed positively. This will stop the glider from stalling again after recovering normal inverted flight attitude and the corresponding negative load factor.

CAUTION:

The elevator control force gradient is unstable (displacement is stable) so that only at fine visual conditions it is possible to maintain the flight speed exactly. With increasing turbulence, increasing importance must be attached to this phenomenon.

If the pilot is no longer able to control the glider due to personal difficulties, the aileron control shall be consistently deflected into one direction until recovery of the normal flight attitude.

- Spin (normal attitude)

CAUTION: Aerobatics are only approved if the fuselage reinforcement according to OSB 315-66 is installed.

Initiation:

Reduce the speed slowly. At 65 - 73 km/h (35 - 39 kts) IAS, first rudder to full deflection, then pull elevator control fully. The glider is spinning slowly.

Rotation speed: 1 revolution / 2-6 sec. The loss of altitude per revolution is appr. 80 - 120 m (262 - 394 ft) plus altitude for levelling off.

Termination:

Rudder control against spin direction, push elevator control. Aileron control to neutral or against turn direction. Level off smoothly after spin has been terminated (+2.5 to +3.5 g).

WARNING:

In general, releasing the controls cannot be regarded as a "simplified" method for spin termination. We also strictly advise you against "termination trials" by aileron deflection into spin direction.

NOTE:

In addition to the standard termination procedure, aileron deflection against spin direction is helpful at any configuration.

For spin, the center of gravity is of extreme importance. It has to be determined before flight and must be within the permitted range in any case.

With forward CoG positions, the "TWIN" will hardly spin. A premature termination of the spin is most probable.

- Spin (inverted attitude)

CAUTION: Aerobatics are only approved if the fuselage reinforcement according to OSB 315-66 is installed.

Initiation:

Slowly reduce speed in the inverted attitude. At 125 km/h (67 kts) IAS, full rudder deflection into the desired direction and then push elevator control fully. As soon as the glider rolls off, add aileron control into inverted spin direction at full deflection. Rotation is uniform, pitch attitude is steep and airspeed indication is appr. 80 km/h (43 kts), after spinning has stabilized. The loss of altitude per rotation is appr. 120 - 170 m (394 - 558 ft). At forward CoG positions, a stationary inverted spin is not possible. The glider proceeds with an inverted spiral dive (pay attention to the airspeed indicator).

Termination:

Rudder control against spin direction, pull control stick back and put aileron control to neutral. Spin is terminated abruptly. If the spin had been terminated level off positively from the steep inverted dive. After normal flight attitude has been obtained, speed will be 190 - 230 km/h (103 - 124 kts), the load factor +2.5 to +3.5 g.

WARNING:

The loss of altitude is much higher in comparison with normal spins. The inverted spin required a pilot to be fully fit. The longer the spin is performed the heavier are the loads on blood circulation during the positive level-off phase (black out). With regard to the pilot's physical strain, orientation ability and discretion, the inverted spin is an aerobatic manoeuvre that tops all manoeuvres, described before. The inverted spin shall be an exercise for advanced students and the highlight of aerobatic instruction.

- Trim of "TWIN III"

CAUTION: Aerobatics are only approved if the fuselage reinforcement according to OSB 315-66 is installed.

The TWIN III is equipped with a spring trim device the peculiar characteristics of which during aerobatic flights should be mentioned briefly.

In general, the trim lever position for inverted flight is "NOSE DOWN" to reduce the necessary elevator control force in the "PUSH" direction. For the glider in inverted position, this means "NOSE UP" i.e. nose up and tail down because "bottom" and "top" are reversed in the inverted position.

If you consider the system as an aircraft related system i.e. without reference to the ground, everything remains as in a normal flight i.e.

"NOSE DOWN" = force towards "PUSH",

"NOSE UP" = force towards "PULL".

- Approved Aerobatic Manoeuvres

CAUTION: Aerobatics are only approved if the fuselage reinforcement according to OSB 315-66 is installed.

We would mention again that only those aerobatic manoeuvres and combinations are permitted, which have previously been described within this document. Any snap or flick manoeuvres as well as manoeuvres with high negative accelerations and reverse flight manoeuvres are prohibited.

- Termination of Aerobatic Flights

CAUTION: Aerobatics are only approved if the fuselage reinforcement according to OSB 315-66 is installed.

- Before Landing

Read the obtained g-values. If you have exceeded the permissible values have the glider checked by an authorized inspector (e.g. the German Prüfer Klasse III) before the next flight. The same applies to exceeding the maximum speed.

NOTE:

If you have exceeded the maximum speed or manoeuvre load during aerobatics interrupt your demonstration and land immediately. G-exceedings during landing are not significant.

In case of overload, the glider has to be inspected carefully:

White spots in the laminate of wing, fuselage and tail connections, cracks, folds, buckles in the surface, unusual difficulty during assembly, or unusual oscillation number.

4.5.10 Flights in Clouds

CAUTION: Flights in clouds are only approved if the fuselage reinforcement according to OSB 315-66 is installed.

The glider must only be operated with the specified minimum equipment according to Sec. 2.12.

Experience shows that the installed airspeed indicating system is not affected by icing.

If the manoeuvring speed $v_A = 185$ km/h (100 kts) has been exceeded unintentionally extend the airbrakes to avoid overstress. Spin shall not be executed as a recovery procedure.

In case of emergency, extend the airbrakes and leave the cloud at a speed of appr. 180 km/h (97 kts).

CAUTION:

Flights in clouds must only be performed by pilots, having the corresponding licence. Adhere strictly to the legal regulations with regard to airspace and the requirements of the equipment to be installed.

=====

G 103 C TWIN III ACRO

=====

PILOT'S OPERATING HANDBOOK

=====

SECTION 5

- 5. Performance
 - 5.1 Introduction
 - 5.2 LBA-Approved Data
 - 5.2.1 Airspeed Indicator System Calibration
 - 5.2.2 Stall Speeds
 - 5.3 Additional Information, not Subject to LBA Approval
 - 5.3.1 Demonstrated Crosswind Performance
 - 5.3.2 Flight Polar
 - 5.3.3 - reserved -
 - 5.3.4 - reserved -
 - 5.3.5 Circling Polar

=====

G 103 C TWIN III ACRO

PILOT'S OPERATING HANDBOOK

=====

5.1 Introduction

This section provides all LBA-approved data for airspeed calibration, stall speeds as well as additional values and data which do not require approval.

The data shown in the following tables have been determined by test flights with a glider in good condition and using average piloting techniques.

=====

B 103 C TWIN III ACRO

=====

PILOT'S OPERATING HANDBOOK

=====

5.2 LBA-Approved Data

5.2.1 Airspeed Indicator System Calibration

The diagram shows the airspeed indication errors induced by the design of the pitot-static system.

Connection of Airspeed Indicator:

- Pitot pressure - green
- Static pressure - colourless

Pitot and static pressure as well as the pressure necessary for the vertical speed indicator are measured in a multi-probe at the vertical fin.

Note: Any IAS values mentioned in this Pilot's Operating Handbook are values displayed on the airspeed indicator, considering the airspeed indicator error to be zero.

G 103 C TWIN III AERO

PILOT'S OPERATING HANDBOOK

Calibration Curve of Airspeed Indication System during
Normal Flight

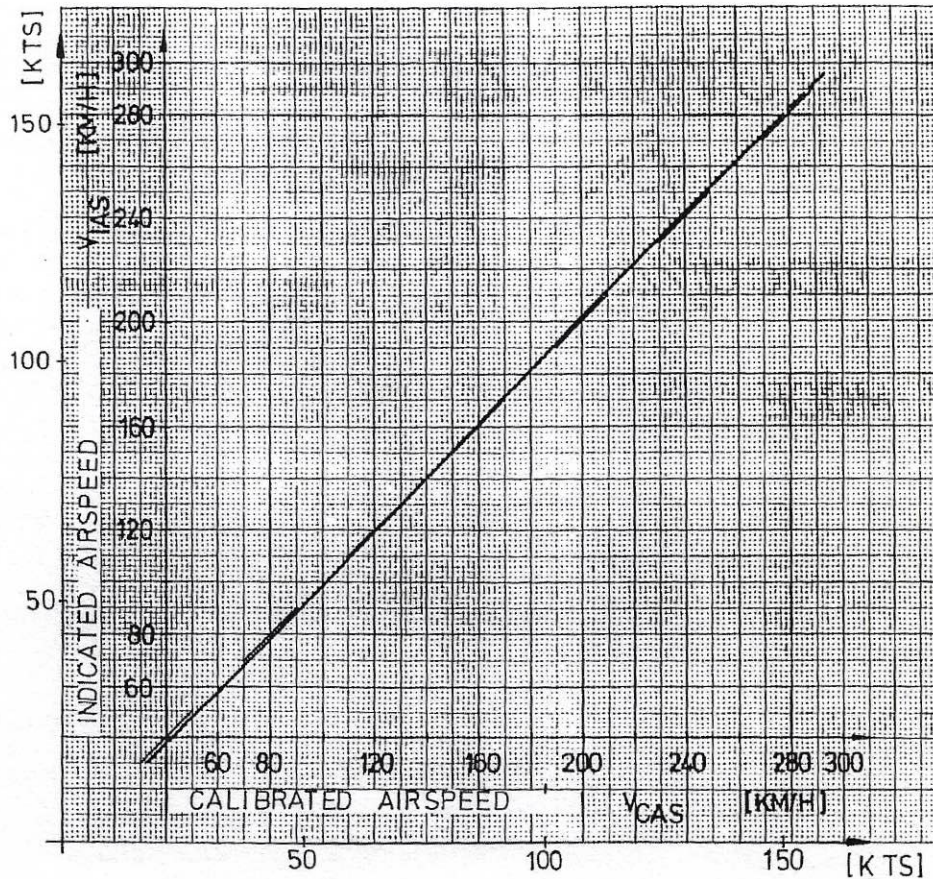

This diagram is valid for

- airbrakes extended and retracted
- forward and aft CoG position
- low and high flight weight
- winch launching
- aero tow

For inverted flight see next page.

Calibration of Airspeed Indication System during
Inverted Flight

V _{IAS} (km/h)	(kts)	V _{CAS} (km/h)	(kts)
150	81	157	85
200	108	193	104
280	151	277	150

5.2.2 Stall Speeds IAS (km/h / kts)

The following stall speeds during level flight have been determined:

Flight weight	450 kg (992 lbs)		530 kg (1168 lbs)		600 kg (1323 lbs)	
	aft		aft		forward	
CoG position	km/h	kts	km/h	kts	km/h	kts
Normal fl. airbr. retr.	61	33	66	36	72	39
warning start	65	35	71	38	--	--
Normal fl. airbr. ext.	66	36	72	39	80	43
warning start	72	39	79	43	--	--
Inverted fl. airbr. retr.	125	67	125	67	125	67
airbrakes extended	112	60	113	61	115	62

This data is valid for an aerodynamically clean aircraft.

- The instrument error has been considered zero.
- Beginning of stall is indicated by tail buffeting.

Note: At max. weight and forward CoG position there is no stall warning because elevator control deflection is acting as angle of attack limit.

The loss of altitude from stalling out to recovering the normal flight attitude shall be up to 50 m (164 ft) (at sea level).

=====

B 103 C TWIN III ACRO

=====

PILOT'S OPERATING HANDBOOK

=====

5.3 Additional Information, not Subject to LBA Approval

5.3.1 Demonstrated Crosswind Performance

Winch-launching	20 km/h	(11 kts)
Aerotow	25 km/h	(13 kts)
Landing	30 km/h	(16 kts)

G 103 C TWIN III AERO

PILOT'S OPERATING HANDBOOK

5.3.2 Flight Polar

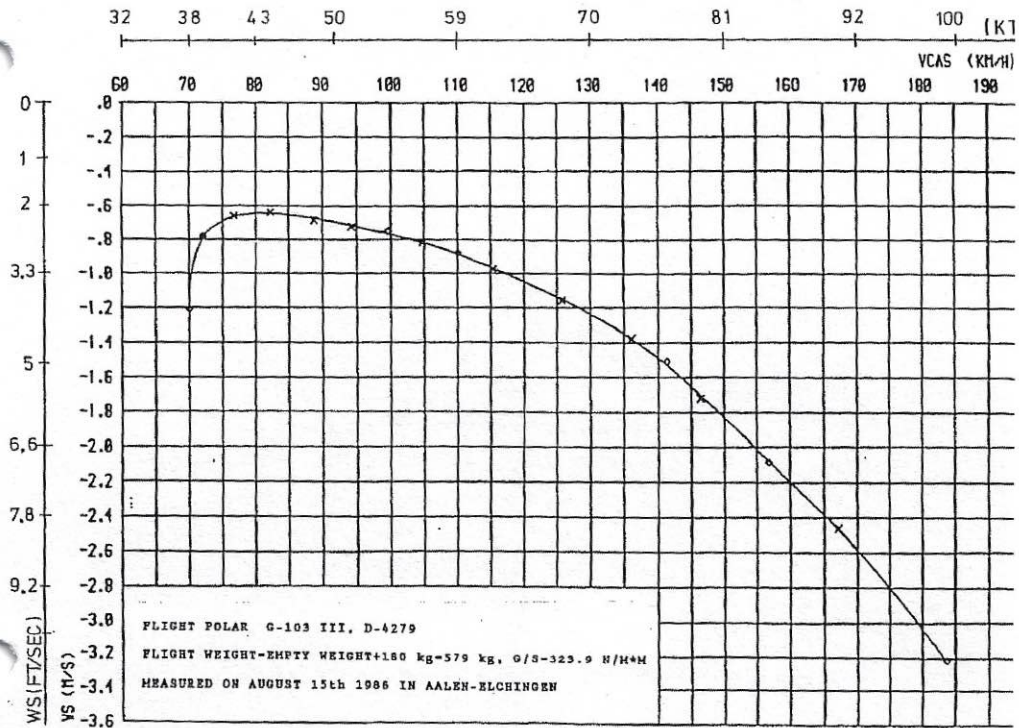

Lowest rate of descent: 0.64 m/sec at 80 km/h
(2.10 ft/sec at 43 kts)
Optimum lift-drag ratio: 37.5 at 95 km/h (51 kts)

Date of Issue: January 1989
Revision:

Page: 5.7

B 103 C TWIN III AERO

PILOT'S OPERATING HANDBOOK

5.3.5 Circling Polar

$n = 579 \text{ kg}$ (1276 lbs)

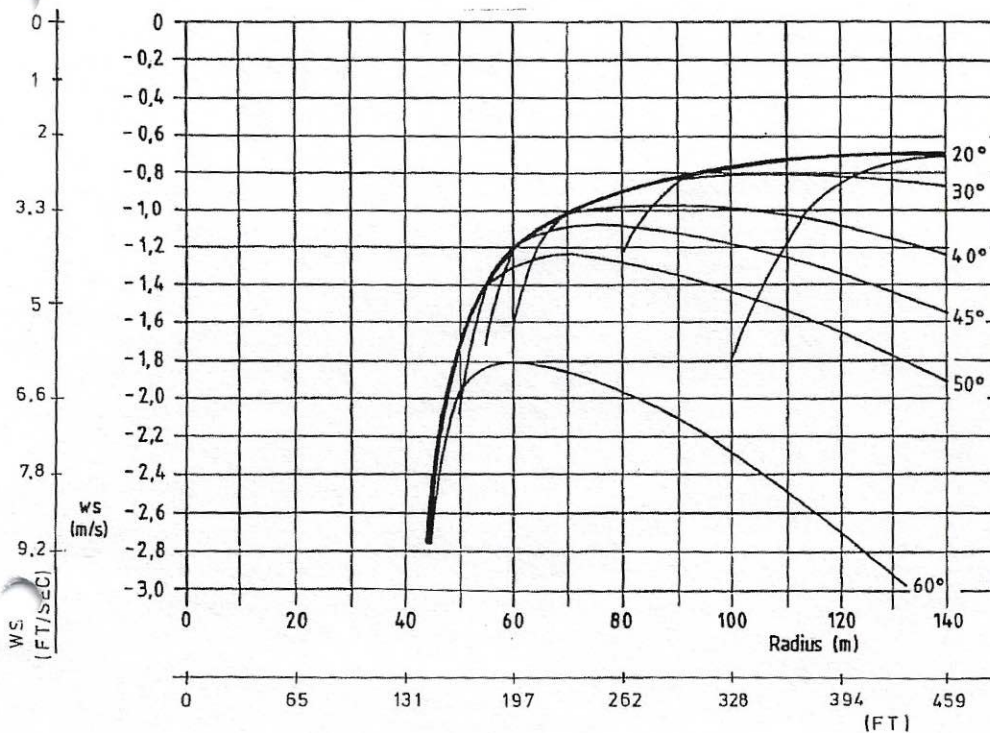

=====

G 103 C TWIN III ADRO

=====

PILOT'S OPERATING HANDBOOK

=====

S E C T I O N 6

- 6. Weight and Balance
- 6.1 Introduction
- 6.2 Weight and Balance Record
Weighing Record

=====

G 103 C TWIN III ACRO

=====

PILOT'S OPERATING HANDBOOK

=====

6.1 Introduction

This section covers empty weight and useful load data which are the basis for the safe operation of the glider.

Methods for determining the empty weight and calculation methods for determining the empty weight CoG as well as a list of the equipment to be considered while weighing can be obtained from the Maintenance Manual of "GROB G 103 C "TWIN ACRO III".

=====

G 103 C TWIN III AERO

=====

PILOT'S OPERATING HANDBOOK

=====

6.2 Weight and Balance Record

After weighing, empty weight, useful load (seats and baggage compartment) as well as empty weight CoG position shall be recorded in the weight and balance record (see next page).

With reference to the weight and balance record, the flight weight CoG position shall always be within the approved operational range.

The weight and balance record is only valid for the glider with the serial number indicated on the front page of this Pilot's Operating Handbook.

In case of not achieving the minimum useful load in the front seat, compensation by addition of lead ballast shall be mandatory. For further details see Page 6.4 .

G 103 C TWIN III ACRO

PILOT'S OPERATING HANDBOOK

Changes of Minimum Load due to Trim Weights

In the front cockpit (left foot space), there is a supporting device (standard equipment) in front of the control stick frame to pick up two trim weights.

Lever arm: 1543 mm (61.06 in.) before datum with 1 trim weight
1560 mm (61.73 in.) before datum with 2 trim weights

The use of trim weights shall be determined by the following placard:

TRIM WEIGHTS				
PILOTS WEIGHT INCLUDING PARACHUTE	kg	55-62.4	62.5-69.9	70-110
	lbs	121-137	138-153	154-242
NUMBER		2	1	0
1 TRIM WEIGHT 5.6 kg (12.3 lbs)				

=====

G 103 C TWIN III ADRO

=====

PILOT'S OPERATING HANDBOOK

=====

Weighing Record

Date of Weighing: performed by:	Equipment List (Date):	Empty Weight of Aircraft (kg):	Empty Weight CoG Position Aft of Datum (mm):	Max. Useful Load (kg): (both seats):	Sig- na- ture

=====

G 103 C TWIN III ACRO

=====

PILOT'S OPERATING HANDBOOK

=====

S E C T I O N 7

- 7. Sailplane and Systems Description
 - 7.1 Introduction
 - 7.2 Cockpit Description
 - 7.3 Instrument Panels
 - 7.4 Airbrake System
 - 7.5 Baggage Compartment
 - 7.6 - reserved -
 - 7.7 - reserved -
 - 7.8 - reserved -
 - 7.9 Electrical System
 - 7.10 Miscellaneous Equipment
 - 7.10.1 Removable Ballast
 - 7.10.2 Oxygen System
 - 7.10.3 Emergency Locator Transmitter

=====

G 103 C TWIN III ACRO

=====

PILOT'S OPERATING HANDBOOK

=====

7.1 Introduction

This section describes the glider, its systems, installed equipment and supplied operational notes for the user.

A detailed description with general drawings is included in the Maintenance Manual.

This section shall describe in particular the controls inside the cockpit and their arrangement.

For further details on additional systems and equipment see Sec. 9.

G 103 C TWIN III ACRO

PILOT'S OPERATING HANDBOOK

7.2 Cockpit Description

- Front Cockpit

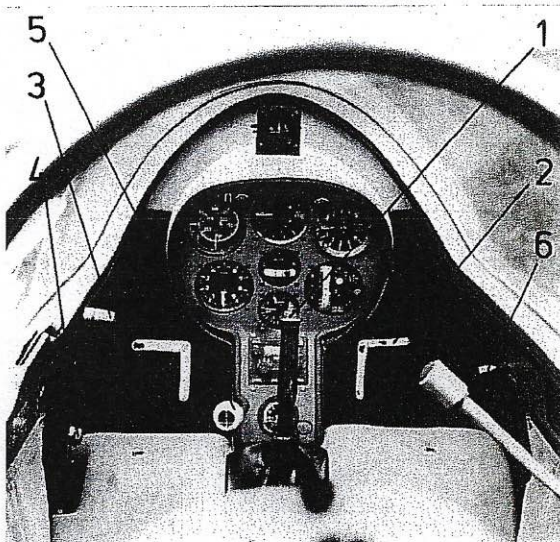

=====

G 103 C TWIN III ACRO

=====

PILOT'S OPERATING HANDBOOK

=====

- Rear Cockpit

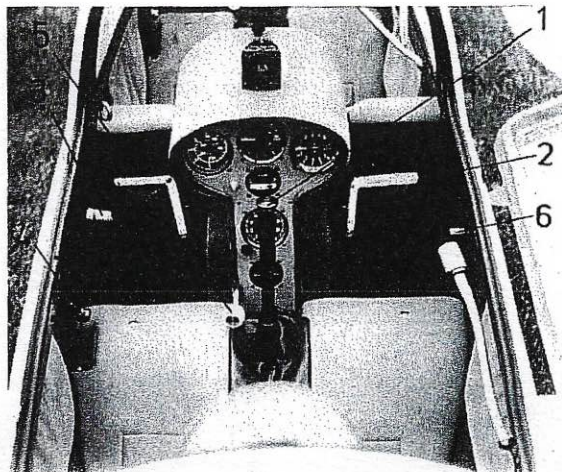

Gauges and controls are in easy reach of the occupants.

After removing the panel fairing (4 quick-locks each) the instruments are easily accessible.

The front panel is mounted to the control stick frame by

two screws and to the fuselage frame by two brackets.

The rear panel is fixed at the control stick frame by two screws and to the center bracket sheets by two screws.

=====

B 103 C TWIN III ACRO

=====

PILOT'S OPERATING HANDBOOK

=====

1 Control Stick

The rear control stick is fixed by a butterfly nut. Care should be taken to ensure this is fully tightened.

Note: Remove the rear stick before passenger flights.

2 Rudder Pedals

3 Airbrake and Wheel Brake Levers

The levers with blue handles which are installed on the left cockpit wall have the following positions:

- forward:	airbrakes locked
- pulled (appr. 4 cm/1.58 in.):	airbrakes unlocked
- backward:	airbrakes fully extended and wheel brake activated

4 Trim Lever

The levers with green handles are the trim levers (left cockpit wall). They are infinitely variable and have the following positions:

- forward:	nose down
- backward:	nose up
- green marking:	normal position

5 Cable Release Device and Towing Hook

The yellow ball handles are installed on the bottom of the panels left of the control sticks.

Cable release is by pulling the handle.

6 Canopy Release

Red levers each on the right cockpit wall.

- forward position:	locked
- backward position:	hinge shaft released

Caution: For canopy release, the canopy lock (left canopy frame) has to be opened simultaneously.

=====

G 103 C TWIN III ACRO

PILOT'S OPERATING HANDBOOK

=====

Canopy Locks (no illustration)

Red levers each on the left cockpit wall.

Forward position: locked
Backward position: unlocked

Caution: Both canopy locks shall have to be checked for
correct locking before each flight.

For emergency procedure for canopy release see Sec. 3.2 .

Canopies

Both canopies hinge to the right. Two different up-locks are
available. First, cable and snap hook and second, canopy
up-lock by means of gas pressure dampers.

Note: See to it that the cables or the dampers respectively
are mounted correctly to keep the hinged canopies open.

Pedal Adjusting Device (no illustration)

- front pedals

Pedal adjustment is by a crank on the right instrument cover
sheet.

- forward adjustment: crank to the left (anti-clockwise)
- backward adjustment: crank to the right (clockwise)

Pedal adjustment is possible either in flight and on ground.

- rear pedals

Separate adjustment of each pedal by releasing and displacing
them on the track on the rear cockpit floor.
Pedal adjustment can be determined visually and should always
be the same on the left and right side.

Ventilation (no illustration)

- ventilation - front cockpit

Small black button on the upper left side of the panel.

- pull: open
- push: closed

The front ventilation also prevents the canopy from being covered with moisture.

- ventilation - rear cockpit

Ventilation nozzle on the right cockpit wall.
Open and close the ventilation system by turning the nozzle insert.

For additional ventilation, open the sliding windows or the traps incorporated in the windows

Wheel Brake (no illustration)

The wheel brake is activated with the airbrakes fully extended.

Nose Wheel Steering (standard as of S/N 34171, no illustration)

The nose wheel steering is linked to the rudder controls by a control cable and two tension springs.

Parachute Static Line Attachment (no illustration)

An orange-red eyebolt on the upper end of the seat shell serves for attaching the static line.

Push-to-Talk Keys (no illustration)

Incorporated in the control stick (standard equipment). If desired, an installation of the rear push-to-talk key in the panel is possible.

7.3 Instrument Panels

- Front panel

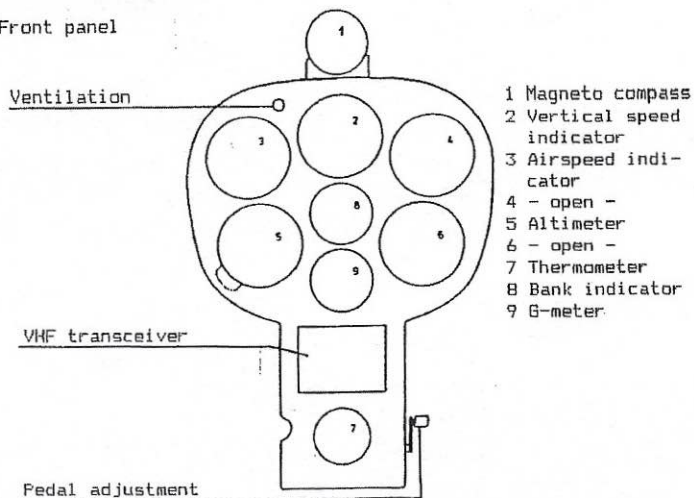

- Rear Panel

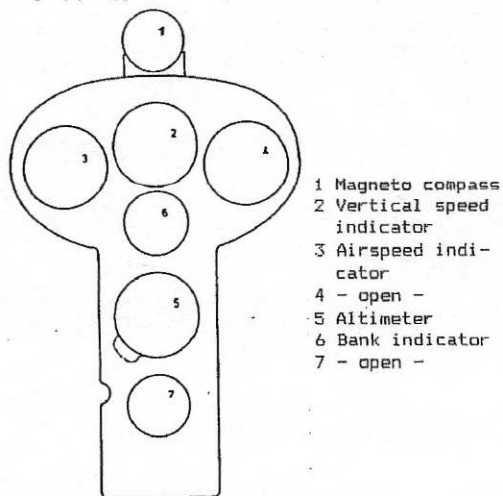

7.4 Airbrake System

The glider is equipped with an airbrake system of type GROB. The airbrakes are mounted on the upper side of the wing. Operation is by airbrake levers in the front and rear cockpit. The levers are mounted on the left side cockpit wall and have blue handles.

With the airbrakes fully extended, the wheel brake is activated.

7.5 Baggage Compartment

The baggage compartment is located in the rear cockpit behind the rear seat above the shutter for the pushrod joints.

On both sides of the baggage compartment floor, there are two eyes each in the fuselage walls to tie down the baggage.

On the baggage compartment floor, there are also mounting supports for battery and barograph.

Baggage: smooth, light objects, only.

Max. loading of the baggage compartment: 10 kg (22 lbs)
(incl. battery)

Warning: Do not take any baggage with you on
aerobatic flights (except for the battery)

7.9 Electrical System

No power supply is necessary to operate the minimum equipment of the glider.

Additional equipment shall be connected to the power supply according to the following wiring diagram.

The battery inside the baggage compartment supplies 12 V DC through an installed fuse. A cable loom leads to a distribution bus below the front panel cover. From the distribution bus, the wiring leads to the different devices and to the distribution bus inside the rear instrument panel.

The standard battery has a capacity of 6.5 Ah.

- Wiring Diagram

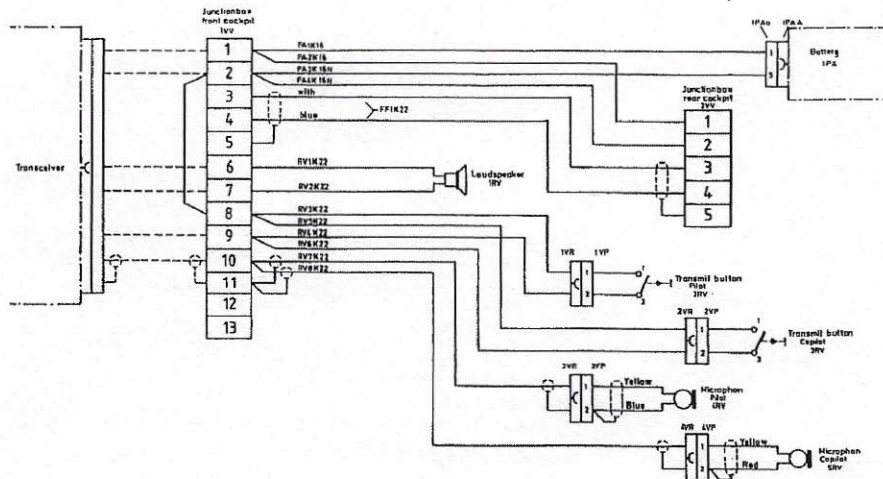

For detailed description see Maintenance Manual Sec. 2.6 .

7.10 Miscellaneous Equipment

7.10.1 Removable Ballast

The front control stick rib (left foot space) is equipped with a mounting support for two trim weights.

The cast trim weights (colour yellow) shall be bolted on two stay bolts and secured by safety pins.

For information on the number of trim weights to be used see Sec. 6.2 .

7.10.2 Oxygen System

Plates with bolts on the right fuselage shell above the baggage compartment for attaching oxygen bottles belong to the standard equipment of the glider. Suitable mounting supports are obtainable from Messrs. Grob. For installation of the oxygen system, drawings are also available.

Note: The Maintenance Manual comprises a list of LBA approved systems.

Caution: After the oxygen system has been installed, the empty weight CoG position shall be determined to prove the CoG.

7.10.3 Emergency Locator Transmitter

Space for mounting an Emergency Locator Transmitter (ELT) is available either on the floor of the baggage compartment or preferably on the shear bottom panel below. The ELT has to be installed in the rear right side (in flight direction).

Installation shall be according to the instructions of the corresponding manufacturer.
In addition, Messrs. Grob provides drawings for ELT installation.

Note: We recommend a remote switch on the front instrument panel.

The Maintenance Manual comprises a list of LBA approved units.

Warning: Special attention should be paid to ensure that the controls are free and movable.

=====

G 103 C TWIN III ADRO

PILOT'S OPERATING HANDBOOK

=====

S E C T I O N 8

8. Sailplane Handling, Care and Maintenance

8.1 Introduction

8.2 Sailplane Inspection Periods

8.3 Sailplane Alterations or Repairs

8.4 Ground Handling / Road Transport

8.4.1 Towing on Ground

8.4.2 Road Transport and Trailer Storage

8.4.3 Parking

8.5 Cleaning and Care

=====

G 103 C TWIN III ACRO

PILOT'S OPERATING HANDBOOK

=====

B.1 Introduction

This section provides recommended procedures for correct ground handling and maintenance of the aircraft. Furthermore, it covers certain inspection and maintenance regulations which have to be adhered to if the glider shall maintain the reliability of a new aircraft.

Caution: Certain lubrication schedules shall be kept and preventive maintenance be conducted based on special climatic and other operating conditions.

8.2 Sailplane Inspection Periods

Maintenance of Airframe

Under normal operating conditions, the airframe is maintenance-free between annual inspections. Other than the connecting points for wing and horizontal tail, mountings do not require any re-lubrication.

According to contamination, clean and lubricate the towing hooks and the wheels, if and when necessary.

The following inspections shall be conducted:

- Annual Inspection
(Inspection schedule see Maintenance Manual Page 4.3)
- Daily Inspection
(see Sec. 4.3)
- Preflight Check
(see Sec. 4.4)
- Unscheduled Inspection
(e.g. after rough landings or ground looping, according to Maintenance Manual Page 4.4 shall be conducted)
- Rudder Cables
Every 200 operating hours and at any annual inspection, the rudder cables shall be checked at the front pedal leading and inside the plastic guide tubes. In case of damage (even on thimbles and clamps), wear or corrosion, the rudder cables have to be replaced.
- Further inspections may be necessary because of the publication of Service Bulletins and Airworthiness Directives (ADs or German LTAs) for the glider or parts of it.

Note: The operator is responsible for the prompt action action of any applicable airworthiness directive.
- Parts with limited life or operating time
(e.g. towing hooks or safety belts may require additional inspections)
(for information referring to this item see Maintenance Manual, Sec. 10)

=====

G 103 C TWIN III ACRO

PILOT'S OPERATING HANDBOOK

=====

B.3 Sailplane Alterations or Repairs

- Alterations

Before conducting any alterations, the responsible registration authorities and the manufacturer shall be informed in order to ascertain that the alteration does not affect the airworthiness of the glider.

- Repairs

Before each flight, in particular after a long period of storage, a ground check shall be made (see also Sec. 4.3). Check for minor variations such as cracks, holes, delamination etc. In any case, consult a FRP expert for damage survey.

The enclosed repair instructions provide information on conducting minor repairs.

Major repairs shall be conducted by the manufacturer or an authorized repair shop only.

=====

B 103 C TWIN III AERO

PILOT'S OPERATING HANDBOOK

=====

8.4 Ground Handling/Road Transport

8.4.1 Towing on Ground

Tow at walking pace only, with a flexible cable in the nose hook and one person at the wing tip and a second near the fuselage (to avoid "rear-end collisions") or with a movable tail wheel device, a drag link and a spring-suspended wheel which is attached to the wing tip by a supporting device (min. width 20 cm/7.91 in.).

If the glider is manually slipped, see to it that people touch the glider near the fuselage to keep the force on the attachment fittings low. The person at the wing tip is only allowed to keep the wings horizontally.

Warning: Pulling the wings is not permitted because this may lead to structural damages inside the wing-fuselage attachment.

Due to structural overstress, it is prohibited to touch the control surfaces for slipping the glider.

8.4.2 Road Transport and Trailer Storage

Closed, weather-resistant trailers shall be provided with adequate ventilation openings.

The different components of the glider must be supported smoothly and be protected against shifting. The storage must be free of tension, in particular at high storage temperature (e.g. in a dark trailer being exposed to sunlight).

- Fuselage

Fuselage undercarriage with shell support in front of the main wheel. Min. length of shell 400 mm (15.83 in.). For holding down the fuselage, the wing attachment fittings may be used. Secure the tail wheel against lateral shifting. Hold down the fuselage rear in front of the vertical fin by means of a carrying strap (min. width 4 cm/1.58 in.). It is also possible to support the nose wheel by means of a wedge.

- Wings

In particular, the wings require correct storage. Min. length of inside support for the spar stub 200 mm (7.91 in.), starting at the root rib. Hold down the spar stub with a carrying strap (min. width 2.5 cm/1 in.). Outside support at the aileron head through a profile-shaped horse (min. length 300 mm/11.87 in., min. height 400 mm/15.83 in.) or a loop with a min. width of 300 mm (11.87 in.)

- Horizontal Tail

Lay it with the upper surface to the ground and hold it down by means of ribbons or put it vertically into profile-shaped horses (leading edge down).

Warning: Never fix the horizontal tail inside the trailer by its attachment fittings.

The support shall be upholstered with rubber sponge or felt.

For the manufacture of fuselage support shells, wing and tail braces, the manufacturer provides the corresponding sectional drawings.

- If trailing lock g-meter.

8.4.3 Parking

Gliders which remain assembled all year round require special care to avoid corrosion of the connecting elements of fuselage, wings and horizontal tail (see Sec. 8.5).

When parking the glider, close the canopies and cover them.

Note: Parking the glider in the open air without protecting it against weather and sunlight does affect the life of the painting. Even after a few weeks without intensive vanish care, the Gel-Coat may become brittle or crack.

We advise you against parking the glider in the open air for a prolonged period.

When storing the assembled glider for a long period of time in a hangar, cover the canopies with dust hoods only because protective covers all over the aircraft would retain moisture for a needlessly long period of time. Moisture does affect the shape and strength of composite material.

- Mooring

Mooring cables may be drawn through the wing tip skids. Additionally, a strap (min. width 4 cm/1.58 in.) may be wound around the tail cone near the vertical fin.

8.5 Cleaning and Care

The entire surface of the glider has been painted with white Polyester Gel-Coat.

Light dirt or dust may be removed with a mild cleaner. Stubborn marks or stains shall be removed with polish. For polishing, use cleaners which do not contain any silicone (e.g. 1 Z - Spezialreiniger - D 2, Messrs. Sauer & Co., D-5060 Bensberg or Reinigungspolish, Messrs. Lesonal).

Ornamented stripes, registration numbers and/or anti-collision painting (if any) are applied using adhesive film or synthetic resin varnish and are not solvent-resistant.

Protect the glider against wetness and moisture. Dry any wet surface as soon as possible. Water which has entered the structure shall be removed by storing the glider in a dry room and by turning the disassembled parts frequently.

Cleaning of the canopies shall be with Flexiklar or a similar plexiglass cleaner or, if need be, with luke-warm water. For removing the water, use a chamois leather or glove fabric only. Never rub plexiglass with dry cloth.

The safety belts shall be frequently checked for damage and wear. The metal parts of the harnesses shall be also frequently checked for corrosion.

Due to its installation in front of the main wheel, the towing hook for winch launching is subject to heavy wear and tear. Therefore, it must be frequently checked for damage, cleaned and lubricated. The hook is easily disconnected after the rear seat shell has been removed. General overhaul shall be made by Messrs. Tost.

Note: The mandatory operating and maintenance instructions published by the safety belt and towing hook manufacturers are applicable.

=====

G 103 C TWIN III ACRO

=====

PILOT'S OPERATING HANDBOOK

=====

Bearings and bolts of the wing and tail joints shall be cleaned and lubricated before assembly of the glider.

The wheel brake of the "TWIN III" has been designed as a disk brake. The brake-master cylinder is located below the rear seat.

Please pay particular attention to the markings for min./max. supply in the brake fluid reservoir.

When refilling, use brake fluid DOT 3/DOT 4 .

G 103 C TWIN III ACRO

PILOT'S OPERATING HANDBOOK

S E C T I O N 9

- 9.1 General
- 9.2 Table of Contents
- 9.3 Supplements



9.1 General

Section 9 of this manual contains information regarding additional (optional) equipment for the saiplane GROB G 103 C TWIN III ACRO. Each supplement relates to a separate equipment item.

All approved supplements are listed in the table of contents of this section.

Ensure that all supplements relating to installed equipment are included in the Flight Manual.

9.2 Table of Contents

Suppl. No.	Title	Reference	Pages	Rev.	LBA approved
1	<ul style="list-style-type: none">• Installation of a manual control for the rudder• Installation of a gate-stop device for the air-brake operating lever	TM 315-53	3	-	Feb. 2, 93 
2	Installation of canards for spin training	TM 315-52	1	-	Jan. 25, 93 

SUPPLEMENT 1

Section 4

NORMAL PROCEDURES

4.2 Rigging and De-Rigging

Installation of the manual control for the rudder and of the gate-stop device for the airbrake operating lever

1. Push the pushrod through the passage in the front seat shell.
2. Push the hand lever onto the tube-stump at the left side wall and secure it with screw and stop nut.
3. Join pushrod to the left pedal drive in the rear seat by means of a quick-lock. Check correct engaging of the quick-lock.
4. Engage pedals in the front seat right in the most forward position.
5. Check function of the rudder control.
6. Check function of the air brake control.
7. Install guide plate for the airbrake gate-stop device at the left side wall. Check function.
8. Placards present?
(refer to Maintenance Manual Chapter 9.2)

Removal is in reverse order.

4.4 Preflight Inspection

- Weight and balance checked?
- Parachutes correctly fitted?
- Safety belts on and fastened correctly?
- Front seat: Pedals adjusted in the most forward position?
Rear seat: Pedals adjusted and/or locked?
- Airbrakes locked after functioning check?
Gate-stop device installed?
- Free motion of controls checked?
- Controls checked with the help of a second person?
Hand lever for manual rudder control secured?
- Trim device adjusted at the green marking?
- Altimeter set?
- Radio set to airfield frequency?
- Canopies closed and locked?
- Correct safety member at the towing cable ?
- Cable correctly hooked ?
- Attention: - crosswind
 - cable break

Section 7

SAILPLANE AND SYSTEMS DESCRIPTION

7.2 Cockpit Description

• Rudder control

On the left cockpit side an orange hand lever is installed for controlling the rudder.

Operating direction: - Lever forward rudder left
 - Lever backward rudder right

Using this installation, the pedals in the front cockpit must be engaged right in the most forward position.

The pushrod for the actuation of the rudder control is joined to the rear left pedal. The movement of the rear pedals is reduced by 35 mm (1.38 in.).

• Airbrakes

Both airbrake operating levers are fixed connected with a pushrod and connected to the rear airbrake trim unit.

After unlocking, the airbrake operating lever can be engaged in the guide plate, which is installed in the front cockpit, in three positions (1,2,3). The last position operates the wheel brake.

The airbrake operating levers are spring-loaded and must be pulled to the inboard direction for operating. By doing this, the airbrake levers are disengaged from the guide plate and may be operated from the rear seat in a normal way.

Note:

This is not the case for the modifications according to AM 315-34107 and AM 315-34156 - here is the airbrake operation from the rear seat only possible, if the pilot in the front seat holds the airbrake lever disengaged.

This special installation may only be installed if the glider is operated by instructed pilots. Before operation of the glider by other pilots the hand lever and the airbrake guide plate must be removed.

SUPPLEMENT 2

Section 4

NORMAL PROCEDURES

4.2 Rigging and De-Rigging

Installation of canards

During installation of the canards please note that the marking R/H and L/H on the canards is with reference to flight direction!

4.5.9 Aerobatics

It is necessary, to install canards on the fuselage nose to achieve stationary spinning during dualseater operation (e.g. for spin training). The canards will cause a nose up moment and therefore destabilize the glider during spinning. Nevertheless the heavier pilot should sit in the rear seat during flight, because stationary spinning is not possible with extreme forward C.G. locations (less than 400 mm/15.7 in.).

The canards can be used through the complete permitted flight envelope. Nevertheless, the canards should be removed during "normal" (non aerobatic) flights.

